

TEKTRONIX®

**AM 501
OPERATIONAL
AMPLIFIER**

INSTRUCTION MANUAL

Tektronix, Inc.
P.O. Box 500
Beaverton, Oregon 97077

Serial Number _____

WARRANTY

Tektronix warrants that this product is free from defects in materials and workmanship. The warranty period is one (1) year from the date of shipment. Tektronix will, at its option, repair or replace the product if Tektronix determines it is defective within the warranty period and if it is returned, freight prepaid, to a service center designated by Tektronix.

Tektronix is not obligated to furnish service under this warranty:

- a. to repair damage resulting from attempts by personnel other than Tektronix representatives to install, repair, or service the product;
- b. to repair damage resulting from improper use or from connecting the product to incompatible equipment;
- c. if personnel other than Tektronix representatives modify the hardware or software.

There is no implied warranty of fitness for a particular purpose. Tektronix is not liable for consequential damages.

Copyright © 1973, 1977 Tektronix, Inc. All rights reserved. Contents of this publication may not be reproduced in any form without the written permission of Tektronix, Inc.

Products of Tektronix, Inc. and its subsidiaries are covered by U.S. and foreign patents and/or pending patents.

TEKTRONIX, TEK, SCOPE-MOBILE, and  are registered trademarks of Tektronix, Inc.

Printed in U.S.A. Specification and price change privileges are reserved.

TABLE OF CONTENTS

		Page
SECTION 1	OPERATING INSTRUCTIONS	1-1
SECTION 2	SPECIFICATION AND PERFORMANCE CHECK	2-1

WARNING

The remaining portion of this Table of Contents lists servicing instructions that expose personnel to hazardous voltages. These instructions are for qualified service personnel only.

SECTION 3	ADJUSTMENT	3-1
SECTION 4	MAINTENANCE AND INTERFACING INFORMATION	4-1
SECTION 5	CIRCUIT DESCRIPTION	5-1
SECTION 6	OPTIONS	6-1
SECTION 7	REPLACEABLE ELECTRICAL PARTS	7-1
SECTION 8	DIAGRAM AND CIRCUIT BOARD ILLUSTRATION	8-1
SECTION 9	REPLACEABLE MECHANICAL PARTS AND EXPLODED VIEW	9-1
CHANGE INFORMATION		

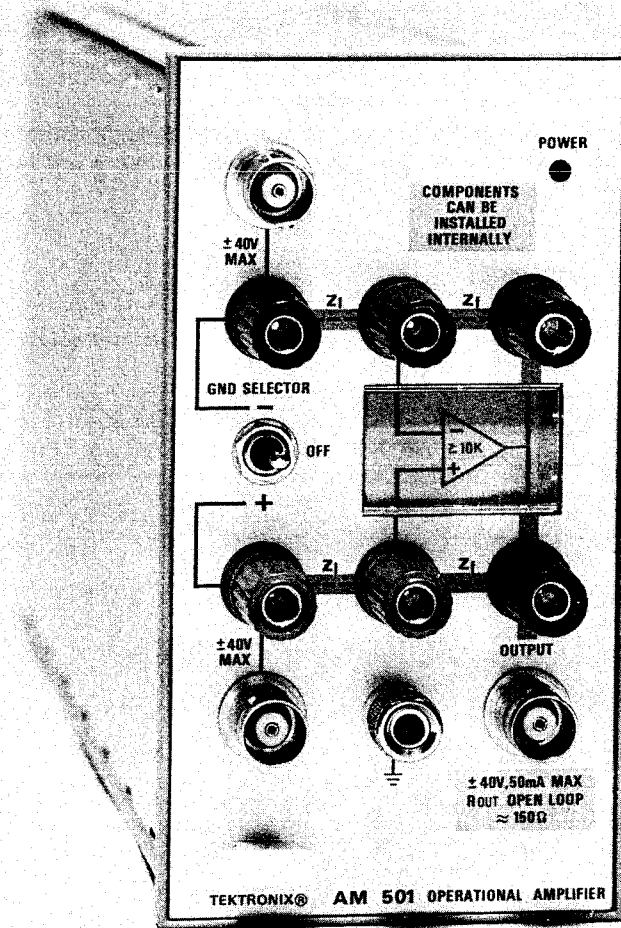

Fig. 1-1. AM 501 Operational Amplifier plug-in unit.

1616-01

OPERATING INSTRUCTIONS

INTRODUCTION

Description

The AM 501 is a high-power operational amplifier unit designed for use in the TM 500 series power modules. The unit has a wide output voltage swing centered at zero, high common-mode range, and a high slewing rate. The AM 501 has convenient front-panel access terminals for connection of feedback resistors to either input, or various input loading configurations. Internal pads on the circuit board permit permanent loading, feedback, or input component connections. A front-panel switch permits selective grounding of either bnc input or binding post connectors. The output may be taken from front-panel binding posts or a bnc connector.

Installation and Removal

CAUTION

Turn the power module off before inserting the plug-in; otherwise, damage may occur to the plug-in circuitry. It is also recommended that the power module be turned off before removing the AM 501. Refer to Fig. 1-2. Check to see that the plastic barriers on the interconnecting jack of the selected power module compartment match the cut-outs in the AM 501 circuit board edge connector.

Align the AM 501 chassis with the upper and lower guides of the selected compartment. Push the module in and press firmly to seat the circuit board in the interconnecting jack.

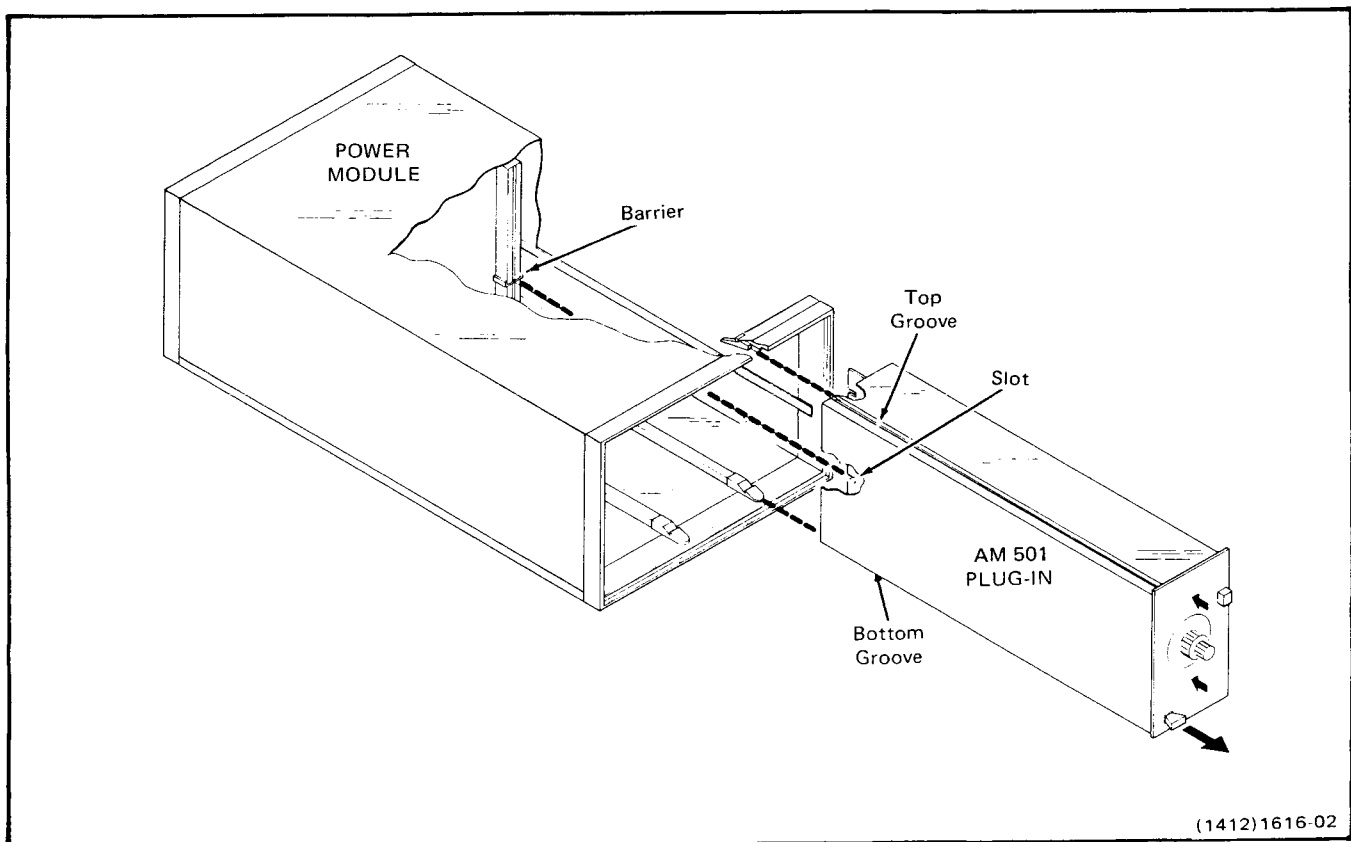

Fig. 1-2. Plug-in module installation/removal.

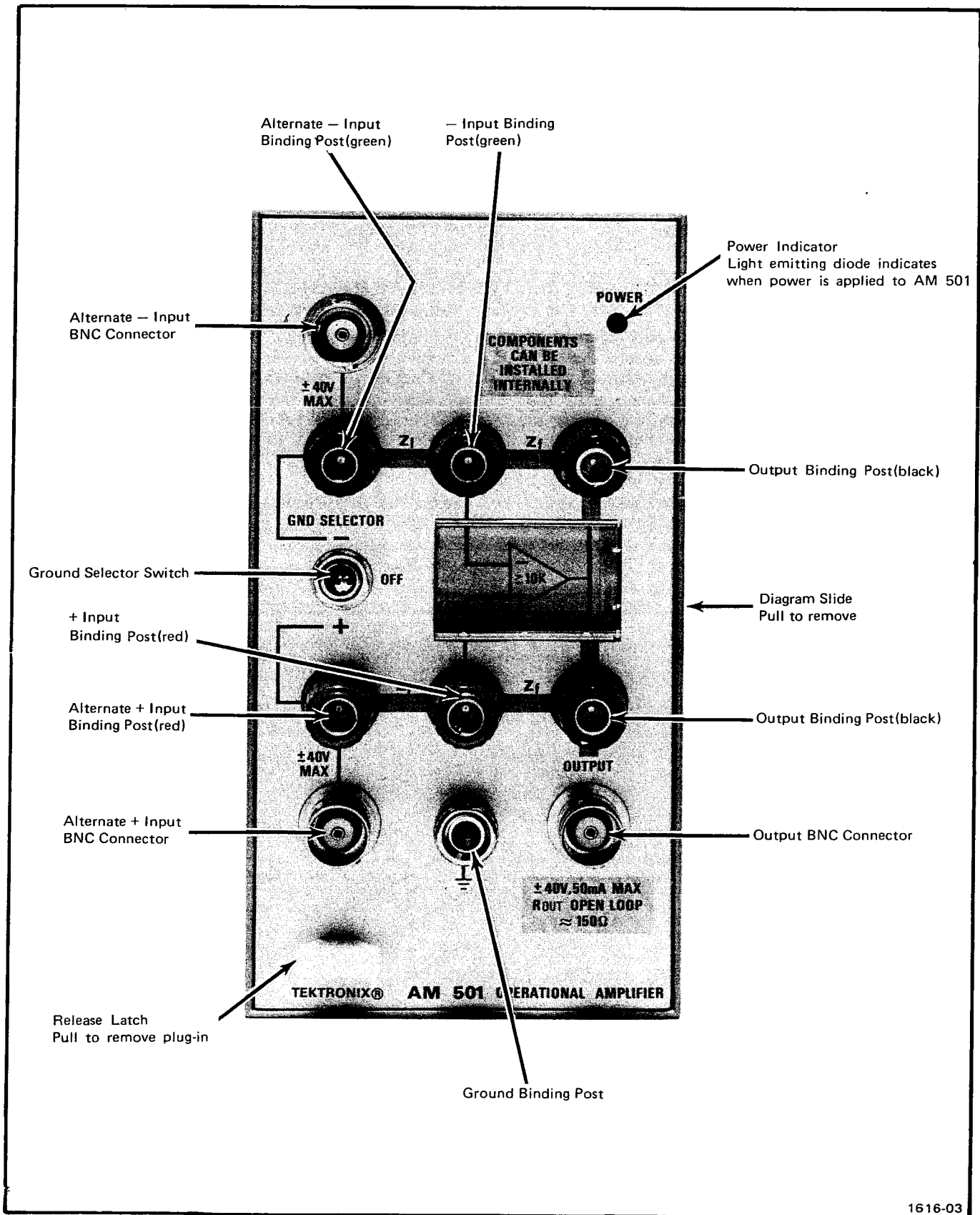

Fig. 1-3. AM 501 controls and connectors.

To remove the AM 501, pull on the release latch located in the lower left corner until the interconnecting jack disengages and the AM 501 will slide out.

Controls and Connectors

Refer to Fig. 1-3. Even though the AM 501 is fully calibrated and ready to use, the functions and actions of the controls and connectors should be reviewed before attempting to use it. Pull the Power switch on the power module to apply power to the AM 501. The POWER indicator light indicates when power is applied to the AM 501.

OPERATING CONSIDERATIONS

Overheating

The AM 501 is designed to operate at an ambient temperature from 0°C to +50°C. However, when operating several power supply plug-ins in a multi-plug-in power module, especially at low plug-in output voltages, or when operating close to other heat-producing equipment, internal temperature may exceed safe limits and actuate a thermal cutout in the power module. Refer to the power module instruction manual for more complete information.

APPLICATION

Introduction

Operational amplifiers such as the AM 501 are useful in simulating a variety of circuits. They are used to add, subtract, differentiate, integrate, and amplify either linearly, or with controlled non-linear coefficients under signal conditions. By using semiconductors or other external active elements, operational amplifiers will perform compression, expansion, root and power functions, limiting, clipping, and fast-response logarithmic amplification.

Some basic operational amplifier symbols and practical circuits are shown in this section. See Fig. 1-4 for basic operational amplifier symbols. If more information about commonly used circuits is desired, refer to the following text books:

David F. Stout, "Handbook of Operational Amplifier Circuit Design", McGraw-Hill, New York, 1976.

Jerald G. Graeme, "Applications of Operational Amplifiers; third generation techniques", McGraw-Hill, New York, 1973.

Arpad Barna, "Operational Amplifiers", Wiley-Interscience, New York, 1971.

Optional Bandwidth Limiting

The AM 501 has a bandwidth of greater than 5 MHz. This bandwidth may be limited by the addition of a capacitor, for a specific application. Have a qualified service person check the operational requirements and placement of the component in the Maintenance Section of this manual.

Practical Circuits

Figs. 1-5 through 1-9 show several practical circuit applications for the AM 501. These circuits illustrate the many possible uses for the AM 501.

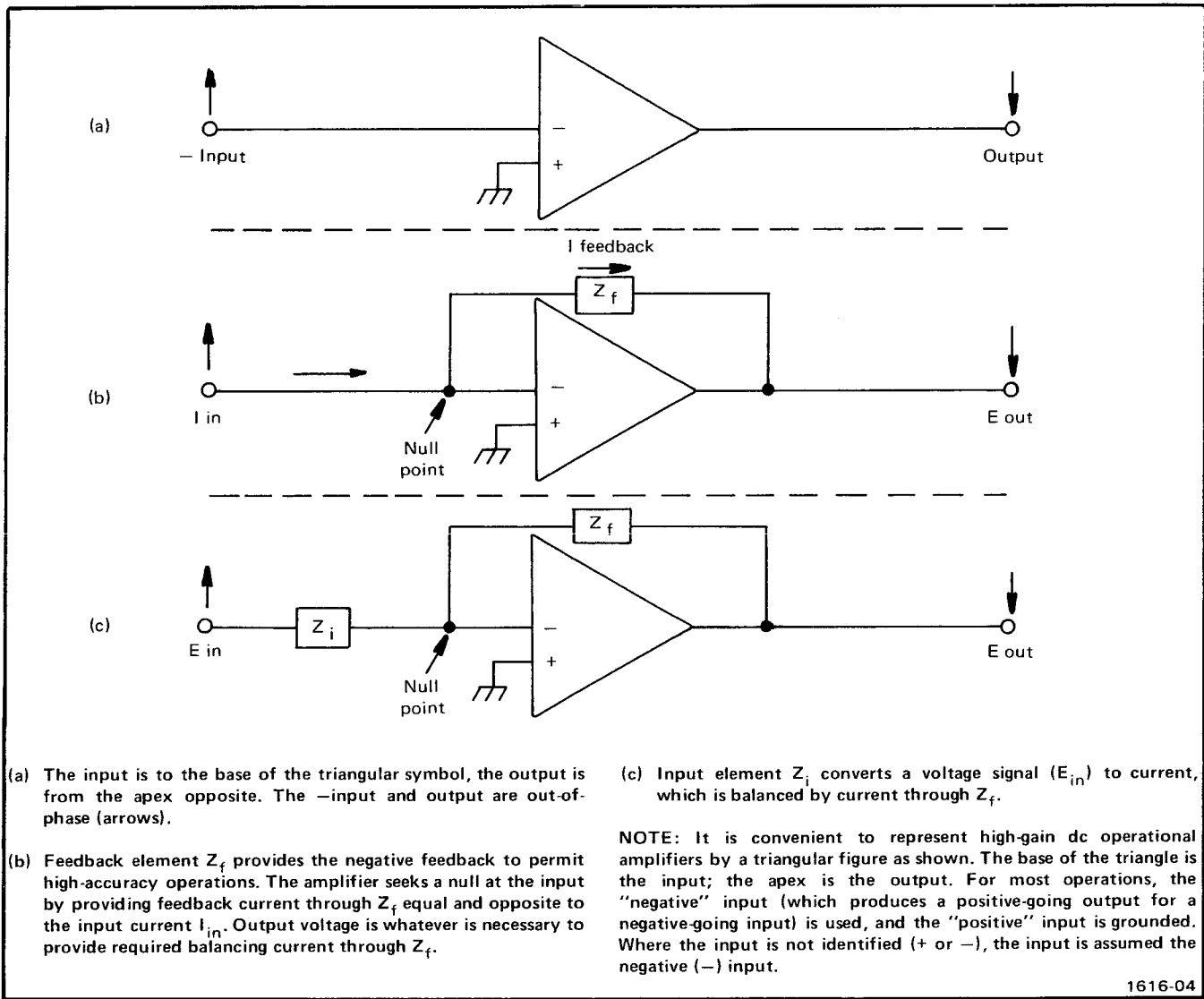

1616-04

Fig. 1-4. Conventional Operational Amplifier symbols

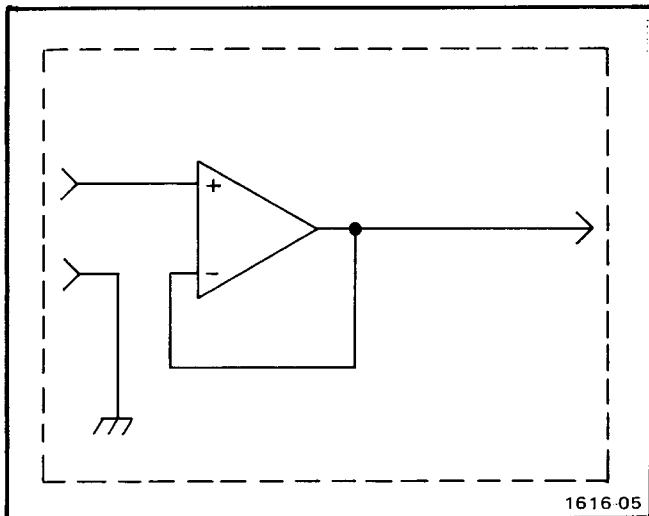

Fig. 1-5. X1 Non-inverting amplifier (follower).

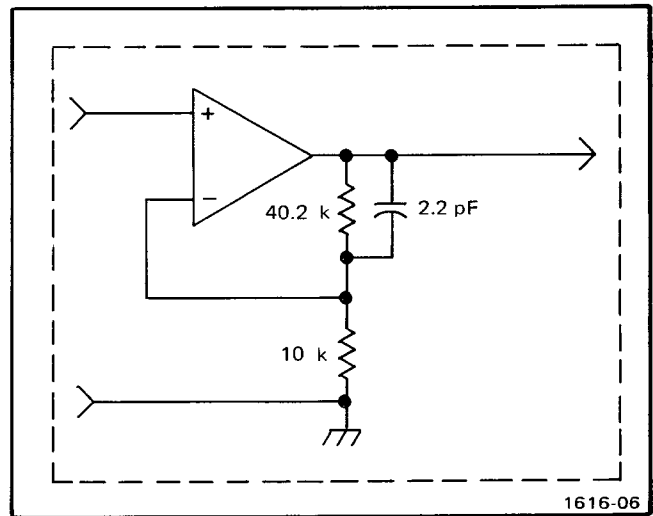

Fig. 1-6. X5 Non-inverting amplifier.

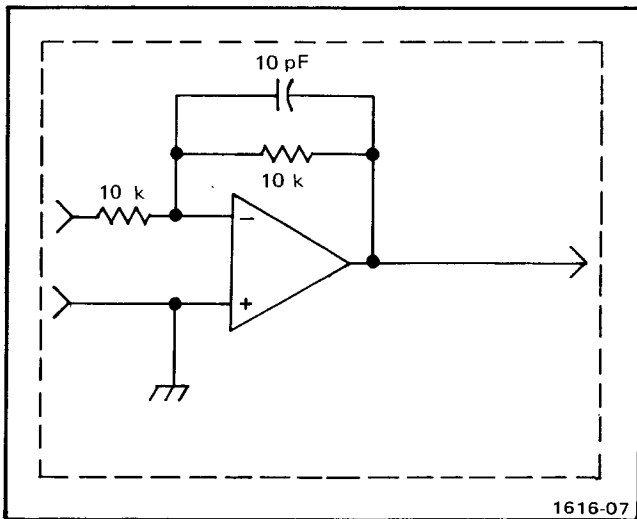

Fig. 1-7. X1 Inverting amplifier.

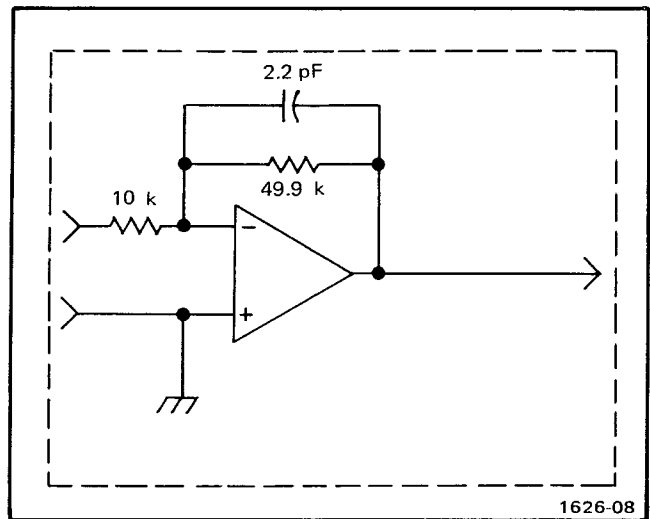

Fig. 1-8. X5 Inverting amplifier.

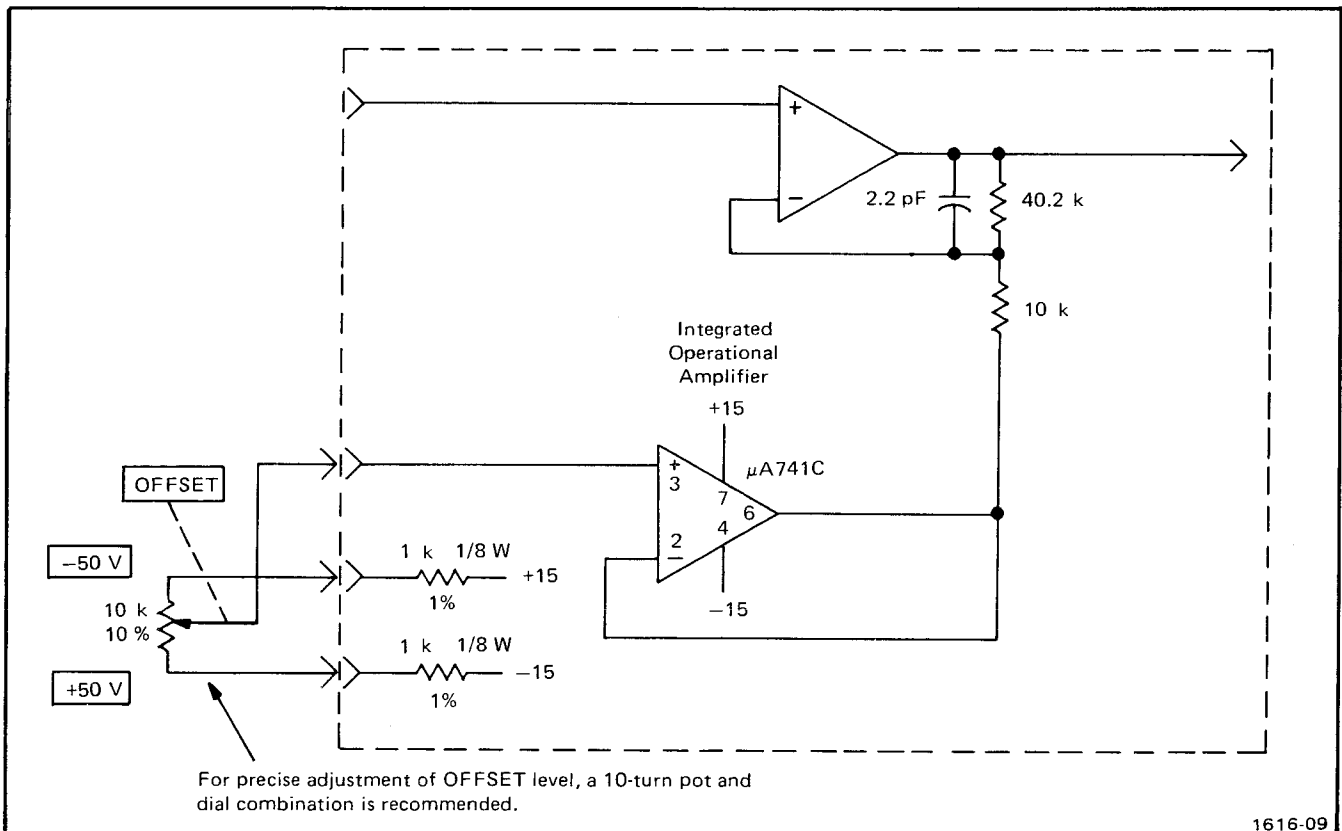

Fig. 1-9. X5 Amplifier with offset.

SPECIFICATION AND PERFORMANCE CHECK

SPECIFICATION

Performance Conditions

The electrical characteristics are valid only if the AM 501 has been calibrated at an ambient temperature between +20°C and +30°C and is operating at an ambient temperature between 0°C and +50°C unless otherwise noted.

Items listed in the Performance Requirements column of the Electrical Characteristics are verified by completing the Performance Check in this manual. Items listed in the Supplemental Information column are not verified in this manual; they are either explanatory notes or performance characteristics for which no limits are specified.

Table 2-1
ELECTRICAL CHARACTERISTICS

Characteristics	Performance Requirements	Supplemental Information
Gain	Open Loop: greater than 10,000 into an 800 Ω load.	
Common Mode Rejection Ratio	Greater than 10,000:1 at 60 Hz.	
Unity Gain Bandwidth	Greater than 5 MHz into an 800 Ω load.	
Input		
Maximum Safe Differential Input Voltage	80 V.	
Common Mode Input Voltage Range	± 40 V.	
Equivalent Input Drift		Less than 100 $\mu\text{V}/^\circ\text{C}$.
Equivalent Input Noise		Less than 10 μV RMS.
Slew Rate	Greater than 50 V/ μs into an 800 Ω load.	
Output		
Voltage Range	Greater than ± 40 V.	
Current Limit	Greater than ± 50 mA.	
Power Consumption		8 watts.
Power Supplies		
Dc Voltages		± 49.6 V to 49.8 V
Ripple		Less than 5 mV measured with a 5 MHz bandwidth oscilloscope.

Table 2-2
ENVIRONMENTAL CHARACTERISTICS

Characteristics	Performance Requirement	Supplemental Information
Temperature Operating Storage	0° C to +50° C. -40° C to +75° C.	
Altitude Operating Storage	To 15,000 feet, maximum operating temperature decreased by 1° C/1,000 feet from 5,000 to 15,000 feet. To 50,000 feet.	
Vibration Operating and Non-operating	With the instrument complete and operating, vibration frequency swept from 10 to 55 to 10 Hz at 1 minute per sweep. Vibrate 15 minutes in each of the three major axes at 0.015 inch total displace- ment. Hold 10 minutes at any ma- jor resonance, or in none, at 55 Hz. Total time, 75 minutes.	
Shock Operating and Non-operating	30 g's, 1/2 sine, 11 ms duration, 3 shocks in each direction along 3 major axes, for a total of 18 shocks.	

Table 2-3
PHYSICAL CHARACTERISTICS

Characteristics	Information
Overall Dimensions (measured at maximum points)	
Height	5.0 in 12.7 cm
Width	2.5 in 6.35 cm
Length	11.8 in 30.0 cm
Net Weight (Instrument Only)	1.8 lb .82 kg

PERFORMANCE CHECK

Introduction

This procedure checks the electrical characteristics of the AM 501 that appear in the Specification section of this manual. If the instrument fails to meet the requirements given in this performance check, the calibration procedure should be performed. This procedure can also be used by an incoming inspection facility to determine acceptability of performance.

The electrical characteristics in Section 2 are valid only if the AM 501 is calibrated at an ambient temperature of +20°C to +30°C and operated at an ambient temperature of 0°C to +50°C. Forced air circulation is required for ambient temperature above +40°C.

Tolerances that are specified in this performance check procedure apply to the instrument under test and do not include test equipment error.

Test Equipment Required

The following test equipment, or equivalent, is required to perform the performance check. Test equipment characteristics listed are the minimum required to verify the performance of the equipment under test. Substitute equipment must meet or exceed the stated requirements. All test equipment is assumed to be operating within tolerance.

Special test devices are used where necessary to facilitate the procedure. Most of these are available from Tektronix, Inc. and can be ordered through your local Tektronix Field Office or representative.

Preliminary Procedure

1. Ensure that all test equipment and the AM 501 under test are suitably adapted to the line voltage to be applied. Refer to the installation section of the power module manual.

Table 2-4
LIST OF TEST EQUIPMENT REQUIREMENTS

Description	Performance Requirements	Application	Examples
Oscilloscope	Bandwidth, dc to 5 MHz; minimum deflection factor, 1 mV/Div; sweep rate, to at least 200 ns/div; accuracy, within 3%. Differential comparator, comparison voltage, 0 V to ±10 V; accuracy, within 0.2%.	Used throughout procedure to provide display	TEKTRONIX 5110, 5A13N, 5B10N Oscilloscope System.
Function Generator	Waveforms, sine and triangle; voltage amplitude, 10 V p-p; frequency range, 60 Hz to 1 MHz; accuracy, within 3%.	Signal generation for Steps 1, 2, 3, and 4.	TEKTRONIX FG 501. ^a
Medium-frequency constant amplitude signal generator.	Frequency, variable to at least 5 MHz; reference frequency, 50 kHz; output amplitude, variable from 0 V to 5 V; accuracy, within 3%.	Signal generation for Step 5.	TEKTRONIX SG 503. ^a
Power module	Accepts TM 500-series plug-ins.	Provides power for FG 501, SG 503.	TEKTRONIX TM 503.
Patch cord	BNC to banana plug-jack, 6 inch.	Used for signal connection in Step 5.	Tektronix Part No. 012-0089-00.
Termination	Impedance, 50 Ω; connectors bnc.	Output termination for signal generator.	Tektronix Part No. 011-0049-01.
Cable (2 required)	Impedance, 50 Ω; type RG-58U; length, 42 inches; connectors, bnc.	Used for signal connections throughout procedure.	Tektronix Part No. 012-0057-01.
Resistor	Fixed, 50 Ω, 1/2 W, 1%.	Used for Steps 4 and 5.	Tektronix Part No. 323-0068-00 (49.9 Ω).

^aRequires TM 500-Series Power Module.

Table 2-4 (cont)
LIST OF TEST EQUIPMENT REQUIREMENTS

Description	Performance Requirements	Application	Examples
Resistor	Fixed, 100 Ω, 1/2 W, 1%.	Used for Steps 6 and 7.	Tektronix Part No. 323-0097-00.
Resistor	Fixed, 800 Ω 1/2 W, 1%.	Used for Steps 3 through 7.	Tektronix Part No. 323-0706-01
Resistor (2 required)	Fixed, 1 k, 1/2 W, 1%.	Used for Steps 1, 3, and 4.	Tektronix Part No. 323-0193-00.
Resistor	Fixed, 2 k, 1/2 W, 1%.	Used for Step 1.	Tektronix Part No. 323-0222-00.
Resistor	Fixed, 10 k, 1/2 W, 1%.	Used for Steps 3 and 4.	Tektronix Part No. 323-0289-00.
Resistor	Fixed, 100 k, 1/2 W, 1%.	Used for Steps 6 and 7.	Tektronix Part No. 323-0385-00.
Resistor	Fixed, 10 MΩ, 1/2 W, 1%	Used for Steps 5, 6, and 7.	Tektronix Part No. 325-0072-00.
Resistor (2 required)	Fixed, 100 MΩ, 1.5 W, 1%.	Used for Step 2.	Tektronix Part No. 325-0094-00.
Capacitor	Tubular, .01 μF, 100 V, dc.	Used for Step 5.	Tektronix Part No. 285-0674-00.
Capacitor	Tubular, Fixed, 1 μF, Poly.	Used for Steps 6 and 7.	Tektronix Part No. 285-1051-00.
Capacitor (2 required)	Fixed, Elect., 6.8 μF, 100 V, Tant.	Used for Step 2.	Tektronix Part No. 290-0486-00.
Switch	Single Pole, Single Throw.	Used for Steps 6 and 7.	Tektronix Part No. 260-0247-00.
Clip Leads	BNC Female to Clip Leads.	Used for Step 1.	Tektronix Part No. 013-0076-00.

2. Ensure that all test equipment is suitably adapted to the applied line voltage.

3. Install the AM 501 into the power module, and if applicable, install the TM 500 series test equipment into the test equipment power module.

4. Connect the equipment under test and the test equipment to a suitable line voltage source. Turn all equipment on and allow at least 20 minutes for the equipment to stabilize.

Initial Control Settings

Set the following controls during warm-up time:

Oscilloscope

Intensity, Focus Set for well-defined trace and normal brightness.
Vert Mode Left
Trig Source Vert Mode

Differential Comparator

Volts/Div 5 V
Variable Fully clockwise (cal)
+ Input dc
- Input gnd
Bandwidth Limit Pushbutton in (10 kHz)

Time Base Plug-In

Time/Div 10 ms
Variable Fully clockwise (cal)
Triggering
+ Slope Pushbutton in
Auto Trig Pushbutton in
AC Coupl Pushbutton in
Source Left
Position Set so trace starts at left side of graticule.
Swp Mag Pushbutton out (off)

PERFORMANCE CHECK PROCEDURE

1. Check Open Loop Gain. Loop gain is greater than 10,000 into an 800 Ω load.

- a. Connect a 50 Ω cable from the function generator output connector to the + input connector of the differential comparator.
- b. Set the function generator controls for a 60 Hz sine wave output signal of two divisions amplitude (10 V).
- c. Connect the 800 Ω, 2 k, and the two 1 k resistors to the terminals of the AM 501 as illustrated in Fig. 2-1.
- d. Remove the 50 Ω cable from the differential comparator, and connect the same cable from the function generator output to the AM 501 upper input connector.
- e. Set the AM 501 GND SELECTOR switch to OFF. This switch should remain off for the entire procedure.

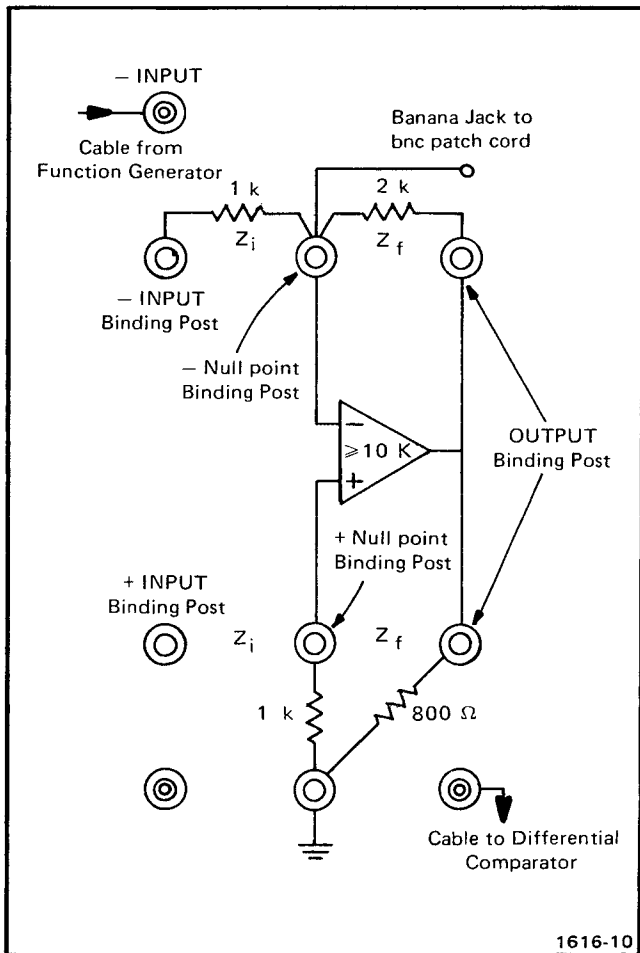

Fig. 2-1. Operational amplifier connected to check open loop gain.

- f. Connect a bnc female to clip leads adapter to the AM 501 minus null point binding post (negative lead to AM 501 ground).
- g. Set the differential comparator volts/div switch to 1 mV.
- h. Connect a 50 Ω cable from the bnc female to clip leads adapter to the + input of the differential comparator.
- i. Check—display is 2 mV peak-to-peak, or less at null point.
- j. Using the formula below, compute Open Loop Gain of AM 501.

Open Loop Gain =

$$\frac{e_{out}}{e_{null}} = \frac{20}{?} \text{ (voltage at AM 501 OUTPUT) = at least 10,000}$$

(voltage on SCOPE)

- k. Disconnect all cables and components.

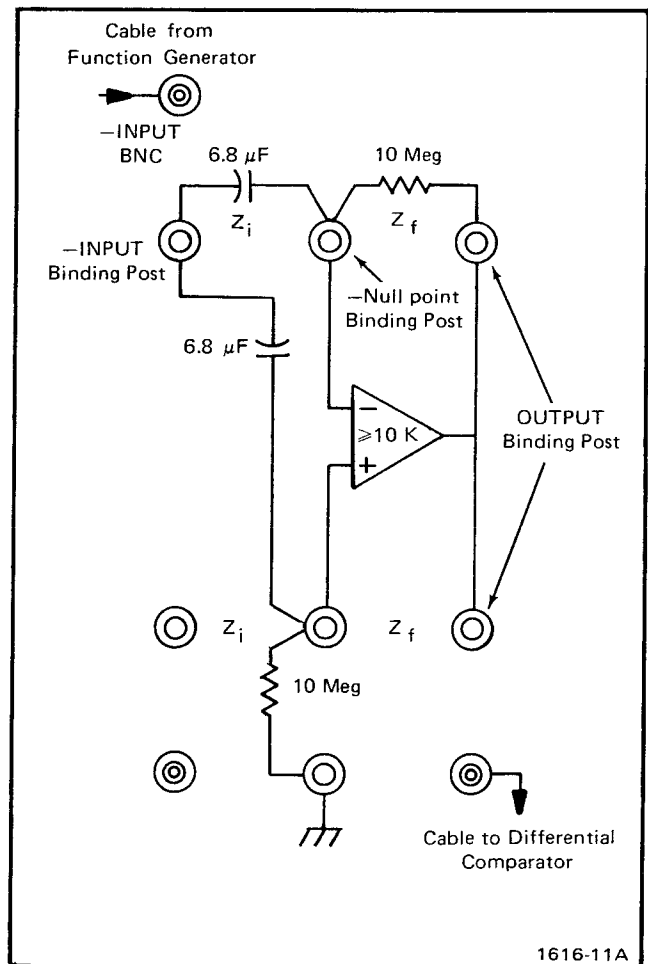

Fig. 2-2. Operational amplifier connected to check Common Mode Rejection Ratio.

Specification and Performance Check—AM 501

2. Check Common Mode Rejection Ratio. Rejection Ratio is greater than 10,000:1 at 60 Hz.

a. Set the differential comparator volts/div switch to 1 V.

b. Connect the two $6.8 \mu\text{F}$ capacitors and the two $100 \text{ M}\Omega$ resistors to the terminals of the AM 501 as illustrated in Fig. 2-2.

c. Connect a 50Ω cable from the function generator output connector to the differential comparator + input connector (+ input to AC).

d. Set the function generator frequency-setting controls for a 60 Hz sine wave output signal.

e. Set the function generator amplitude control to obtain a 4 volt output signal (four division display).

f. Disconnect the 50Ω cable from the differential comparator + input connector and connect it to the AM 501 upper input connector.

g. Connect a 50Ω cable from the AM 501 OUTPUT bnc connector to the differential comparator + input connector.

h. Using the formula below, compute common Mode Gain of AM 501.

Common Mode Gain = e_{out} = (voltage at AM 501 OUTPUT)

e_{in} (output voltage from function generator)

i. Using the formula below, compute common Mode Rejection Ratio (CMRR).

CMRR = $\frac{\text{open loop gain (from step 1)}}{\text{common mode gain (from step 2)}}$

j. Check—CMRR is equal to or greater than 10,000.

3. Check Common Mode Input Voltage Range. Voltage is $\pm 40 \text{ V}$.

a. Set the differential comparator volts/div switch to 2 V.

b. Connect the 800Ω , 10 k , and the two 1 k resistors to the terminals of the AM 501 as illustrated in Fig. 2-3.

c. Connect a 50Ω cable from the function generator output connector to the differential comparator – input connector.

d. Set the function generator frequency-setting controls for a 100 Hz triangle output signal.

e. Set the function generator amplitude control to obtain a ten volt output signal (five-division display).

f. Set the time-base unit to 2 ms/div.

g. Disconnect the 50Ω cable from the differential comparator – input connector and connect it to the AM 501 – input bnc connector.

h. Connect a 50Ω cable from the AM 501 output bnc connector to the differential comparator + input connector.

i. Set the + input coupling to gnd (gnd pushbutton in) on the differential comparator. Position the display to the center of the graticule area.

j. Disconnect the + input coupling from gnd. Do not disturb the Position control during the remaining parts of this step.

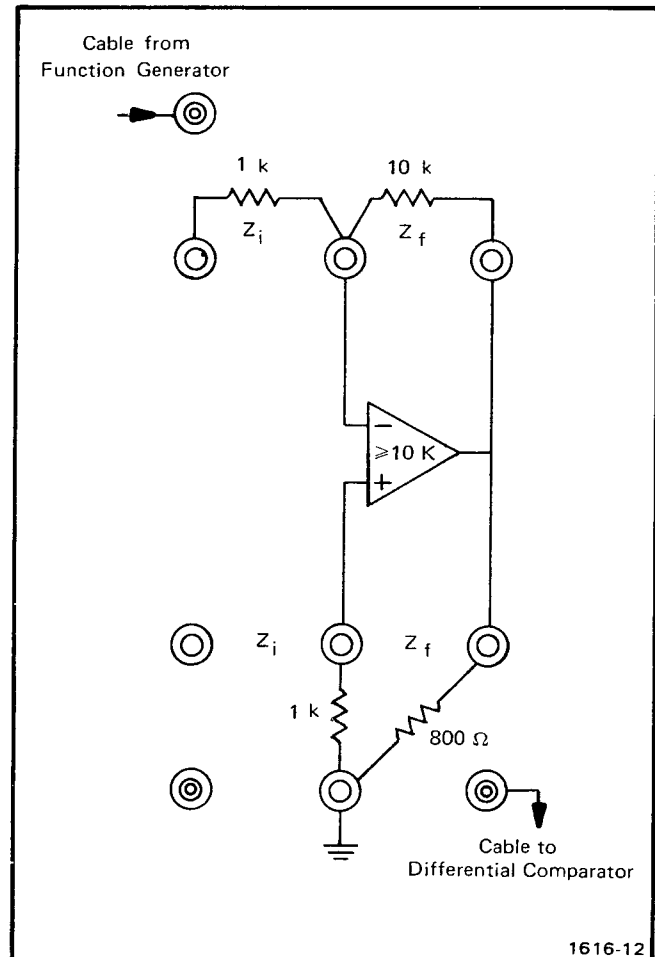

Fig. 2-3. Operational amplifier connected to check Common Mode Input Voltage Range.

k. Set the differential comparator comparison voltage (V_c) control dial to 4.0 (product of the V_c and the attenuation factor of the input attenuator must be equivalent to +40 volts, as applied to the input stage).

l. Apply the V_c to the differential comparator – input (V_c pushbutton in).

m. Check—that top of display is above the graticule center.

n. Disconnect the 50 Ω cable from the differential comparator + input connector and connect it to the – input connector.

o. Remove the V_c from the – input connector (V_c pushbutton out), and apply the V_c (V_c pushbutton in) to the + input connector.

p. Check—that the bottom of display is below the graticule center.

q. Disconnect the 50 Ω cable from the – input connector and connect it to the + input connector.

4. Check Slew Rate. Slew Rate is greater than 50 V/ μ s into an 800 Ω load.

a. Set the differential comparator – Input to GND and the + Input to ac, and the volts/div switch to 5 V.

b. Connect a 50 Ω resistor between the AM 501 input terminals as illustrated in Fig. 2-4.

c. Set the function generator frequency-setting controls for a 100 kHz square-wave output signal.

d. Set the function generator amplitude control to obtain a six-division display.

e. Set the time-base unit to 200 ns/div.

f. Position the rising portion of the display to the center of the graticule area and adjust the time-base triggering controls for a stable display.

g. Check—that the center portion of the trace rises two vertical divisions within one horizontal division (10 V during a 200 ns interval).

h. Disconnect all cables and components.

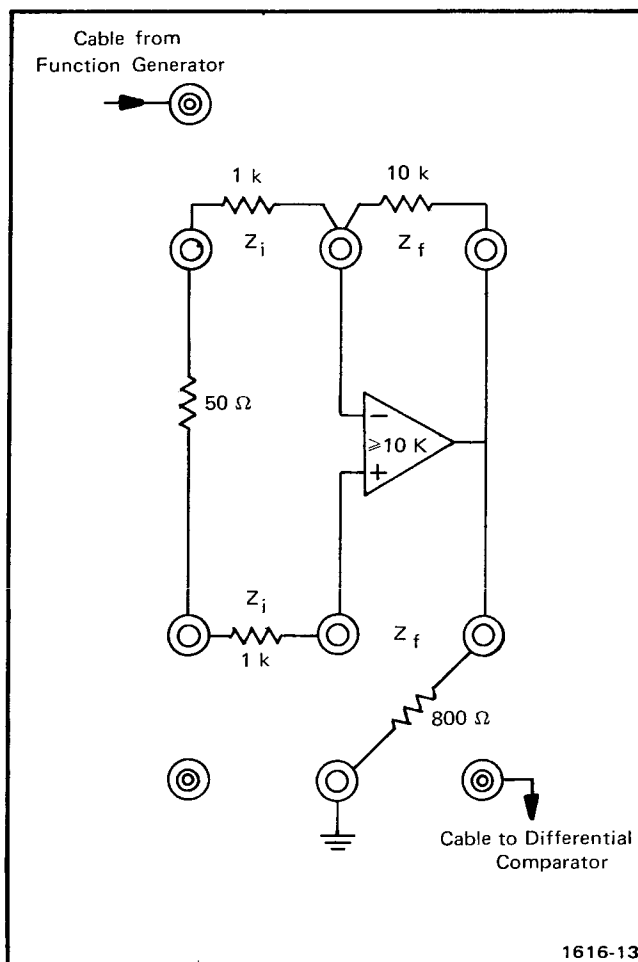

Fig. 2-4. Operational amplifier connected to check Slew Rate.

5. Check Unity Gain Bandwidth. Bandwidth is greater than 5 MHz into an 800 Ω load.

a. Connect the 800 Ω , 50 Ω , 10 M Ω resistors, and .01 μ F capacitor to the terminals of the AM 501 as illustrated in Fig. 2-5.

b. Set AM 501 GND SELECTOR switch to OFF.

c. Set the sine-wave generator frequency-setting controls for a 5 MHz output signal.

d. Connect a 50 Ω cable and a 50 Ω termination from the sine-wave generator output connector to the differential comparator + input connector.

e. Set generator for a 2 volt output at 5 MHz.

f. Disconnect the 50 Ω cable and termination from the differential comparator input and attach the 50 Ω cable and termination to the AM 501 + input connector. Short the two red binding posts (+ inputs) together.

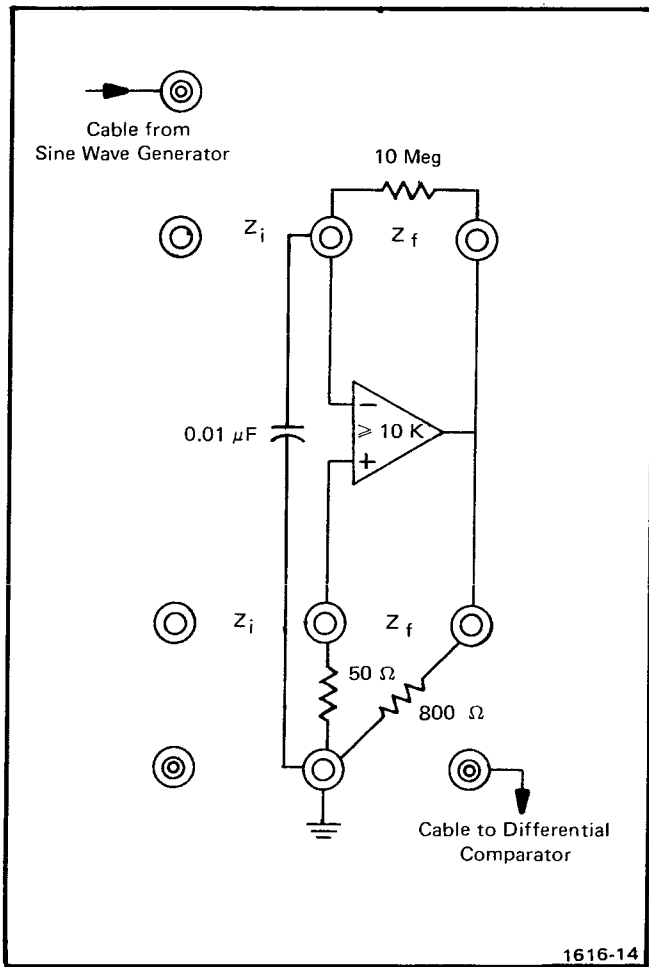

Fig. 2-5. Operational amplifier connected to check Unity Gain Bandwidth.

g. Connect a 50 Ω cable from the AM 501 OUTPUT bnc connector to the differential comparator + input. Set the volts/div switch to 0.5 V.

h. Check—that the output voltage is at least 1 volt peak-to-peak (two division display).

i. Disconnect all cables, termination, patch-cord, and components.

6. Check-Input Leakage Current. Leakage current is less than 500 pA at 25° C, less than 2.0 nA at 50° C.

a. Connect the 800 Ω, 100 k, 100 Ω, 10 MΩ, 1 μF capacitor, and the SPST switch to the terminals of the AM 501 as illustrated in Fig. 2-6.

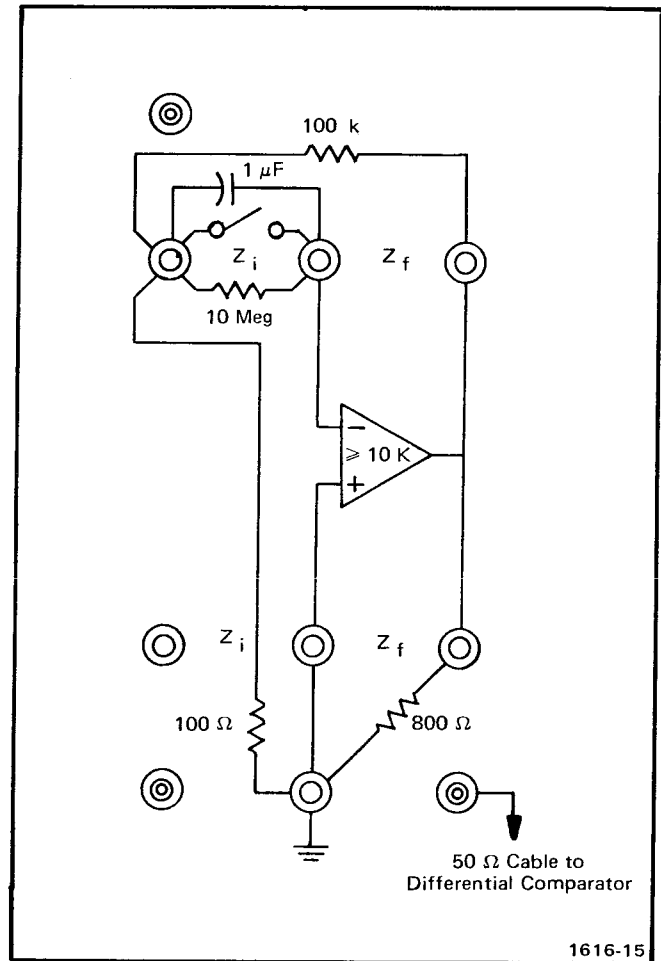

Fig. 2-6. Operational amplifier connected to check Leakage Current for - Input.

b. Connect a 50 Ω cable from the AM 501 OUTPUT connector to the differential comparator - input connector.

c. Set the time-base unit to 1 ms/div.

d. Set the differential comparator volts/div switch to 5 V.

e. Position the trace display to coincide with the center horizontal graticule line.

f. Check—that opening and closing the switch does not cause the trace to change more than one division in one minute.

g. Disconnect all components.

7. Check + Input Leakage Current. Leakage current is less than 500 pA at 25° C, less than 2.0 nA at 50° C.

- a. Connect the 800 Ω, 100 k, 100 Ω, 10 MΩ, 1 μF capacitor, and the SPST switch to the terminals of the AM 501 as illustrated in Fig. 2-7.
- b. Connect a 50 Ω cable from the AM 501 OUTPUT connector to the differential comparator – input connector.
- c. Set the time-base unit to 1 ms/div.
- d. Set the differential comparator volts/div switch to 5 V.
- e. Position the trace display to coincide with the center horizontal graticule line.
- f. Check—that opening and closing the switch does not cause the trace to change more than one division in one minute.
- g. Disconnect all components. This completes the Performance Check procedure.

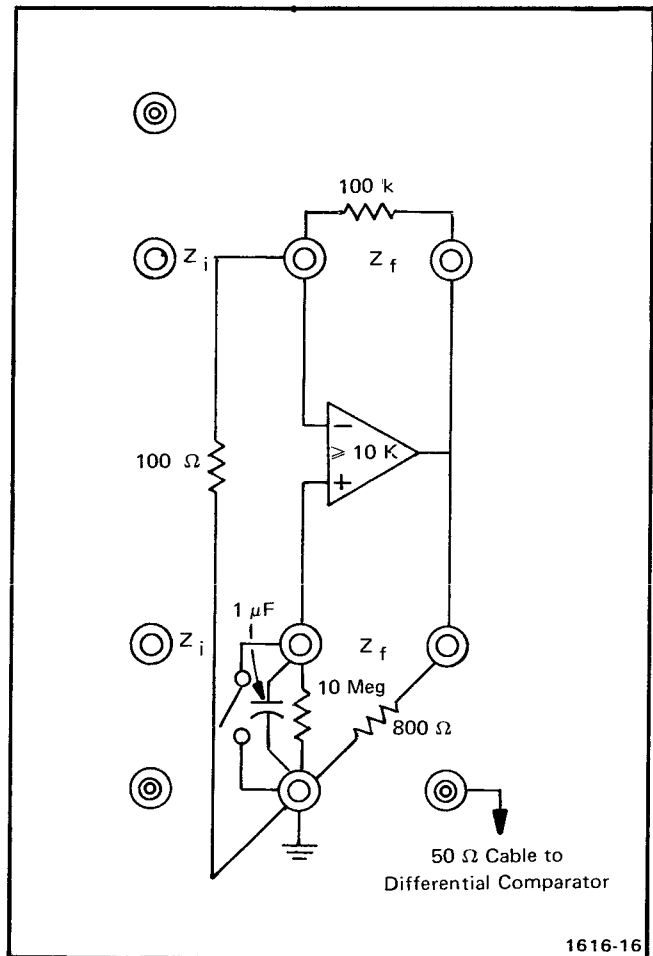

Fig. 2-7. Operational amplifier connected to check Leakage Current for + Input.

WARNING

THE FOLLOWING SERVICING INSTRUCTIONS ARE FOR USE BY QUALIFIED PERSONNEL ONLY. TO AVOID PERSONAL INJURY, DO NOT PERFORM ANY SERVICING OTHER THAN THAT CONTAINED IN OPERATING INSTRUCTIONS UNLESS YOU ARE QUALIFIED TO DO SO.



ADJUSTMENT

Introduction

This adjustment procedure is to be used to restore the AM 501 to original performance specifications. Adjustment need not be performed unless the instrument fails to meet the Performance Requirements of the Electrical Characteristics listed in the Specification section, or the Performance Check cannot be completed satisfactorily.

Completion of all adjustment steps in this procedure ensures that the instrument will meet the performance requirements listed in the Specification section. However, to fully ensure satisfactory performance, it is recommended that the Performance Check be performed after any adjustment is made.

Services Available

Tektronix, Inc. provides complete instrument repair and adjustment at local Field Service Centers and at the Factory Service Center. Contact your local Tektronix Field Office or representative for further information.

Test Equipment Required

The test equipment listed in Table 3-1, or equivalent, is required for adjustment of the AM 501. Specifications given for the test equipment are the minimum necessary for accurate adjustment and measurement. All test equipment is assumed to be correctly calibrated and operating within specification.

If other test equipment is substituted, control settings or calibration setup may need to be altered to meet the requirements of the equipment used.

A flexible plug-in extender, Tektronix Part No. 067-0645-02, is useful for troubleshooting or adjusting the AM 501; however, the complete Adjustment Procedure can be performed without use of the extender.

Preparation

a. Remove the left side cover of the AM 501 to gain access to the component side of the circuit board. Pull the rear end of the side cover outward from the side of the instrument (the cover snaps into place).

b. Install the AM 501 into the left power module compartment, or if appropriate, connect the AM 501 to the power module by means of the flexible plug-in extender.

c. Set the power module for the line voltage to be applied (see power module manual) and connect it to the line voltage source. Be sure that the power switch is off.

d. Install the TM 500-series equipment, including the AM 501 into the power module.

e. Connect all test equipment to a suitable line voltage source.

f. Turn on all test equipment and allow at least 20 minutes for the equipment to warm up and stabilize.

Table 3-1

LIST OF TEST EQUIPMENT REQUIREMENTS

Description	Performance Requirements	Application	Example
Digital voltmeter	Range, 0 to 50 V; accuracy, within 0.1%.	LV power supply and Offset Null adjustment.	TEKTRONIX DM 501 Digital Multimeter. ^a
Resistor	Fixed, 800 Ω 1/2 W 1%.	Offset Null adjustment.	Tektronix Part No. 323-0706-01
Resistor	Fixed, 1 K Ω , 1/2 W 1%.	Offset Null adjustment.	Tektronix Part No. 323-0193-00.

^aRequires TM 500-Series Power Module

Adjustment—AM 501

1. Adjust Positive Voltage Supply

a. Connect the digital voltmeter between the Positive Supply test point on the circuit board, and chassis ground. See Fig. 3-1 for voltage test point location.

b. Check—for a meter reading of +49.6 to +49.8 volts.

c. Adjust—Plus Adj, R10, for a meter reading of +49.7 volts ± 0.1 volt. See Fig. 3-1 for adjustment location.

2. Adjust Negative Voltage Supply

a. Connect the digital voltmeter between the Negative Supply test point on the circuit board, and chassis ground. See Fig. 3-1 for voltage test point location.

b. Check—for a meter reading of -49.6 to -49.8 volts.

c. Adjust—Minus Adj, R12, for a meter reading of -49.7 volts ± 0.1 volt. See Fig. 3-1 for adjustment location.

3. Adjust Offset Null

a. Connect a jumper from the upper OUTPUT binding post (black) to the - input binding post (green). Connect the 1 k resistor from the + input binding post (red) to the ground binding post directly below. Connect the 800 Ω resistor from the OUTPUT binding post (black) to the ground binding post.

b. Connect the digital voltmeter between the OUTPUT binding post (black) and chassis ground.

c. Check—for a meter reading of zero volts (adjust meter to lowest scale).

d. Adjust—Offset Null, R122, for a meter reading of zero volts. Disconnect the digital voltmeter.

e. This completes the adjustment portion of this procedure. However, to verify satisfactory performance after adjustment, perform the complete Performance Check procedure as specified in Section 2 of this manual.

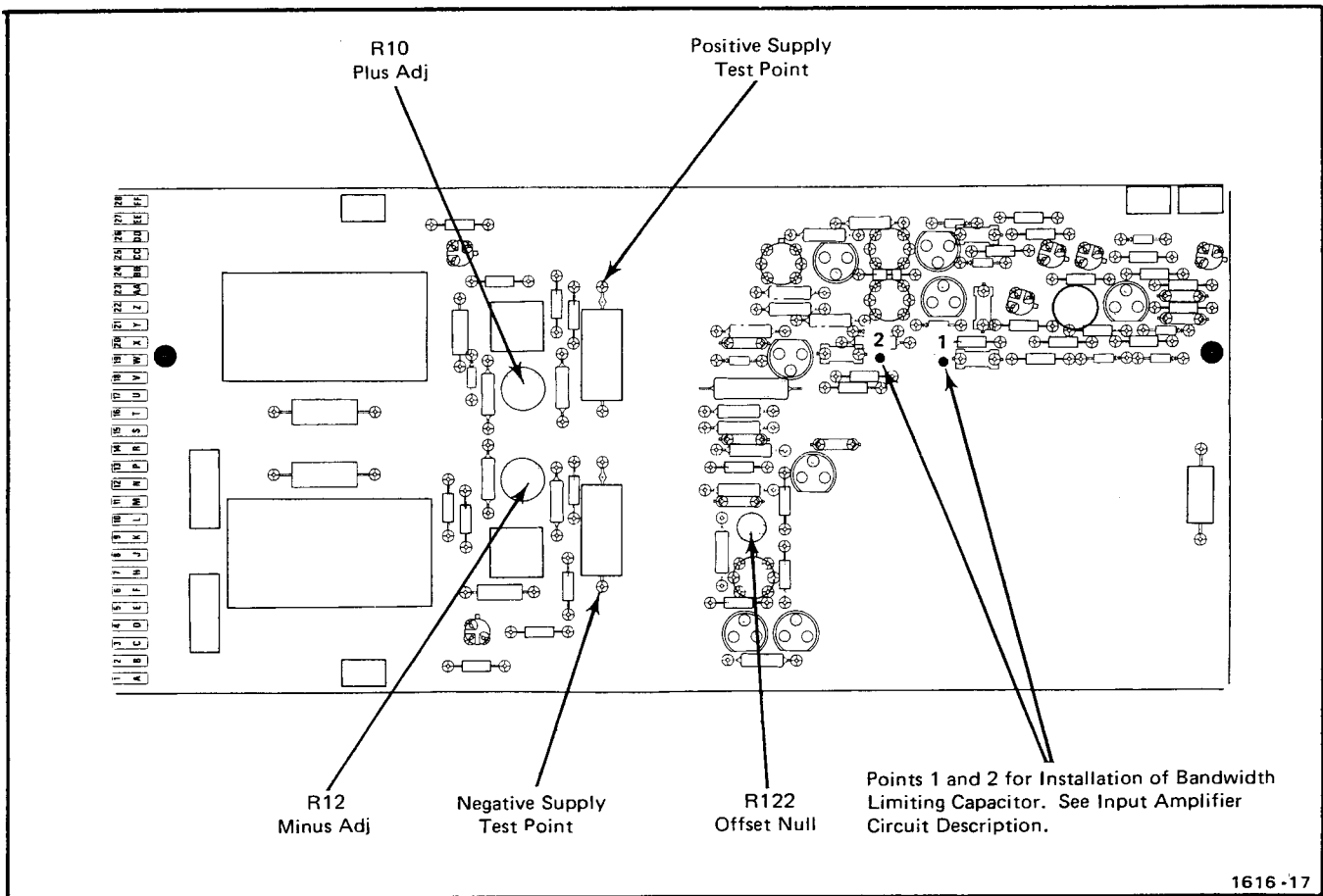
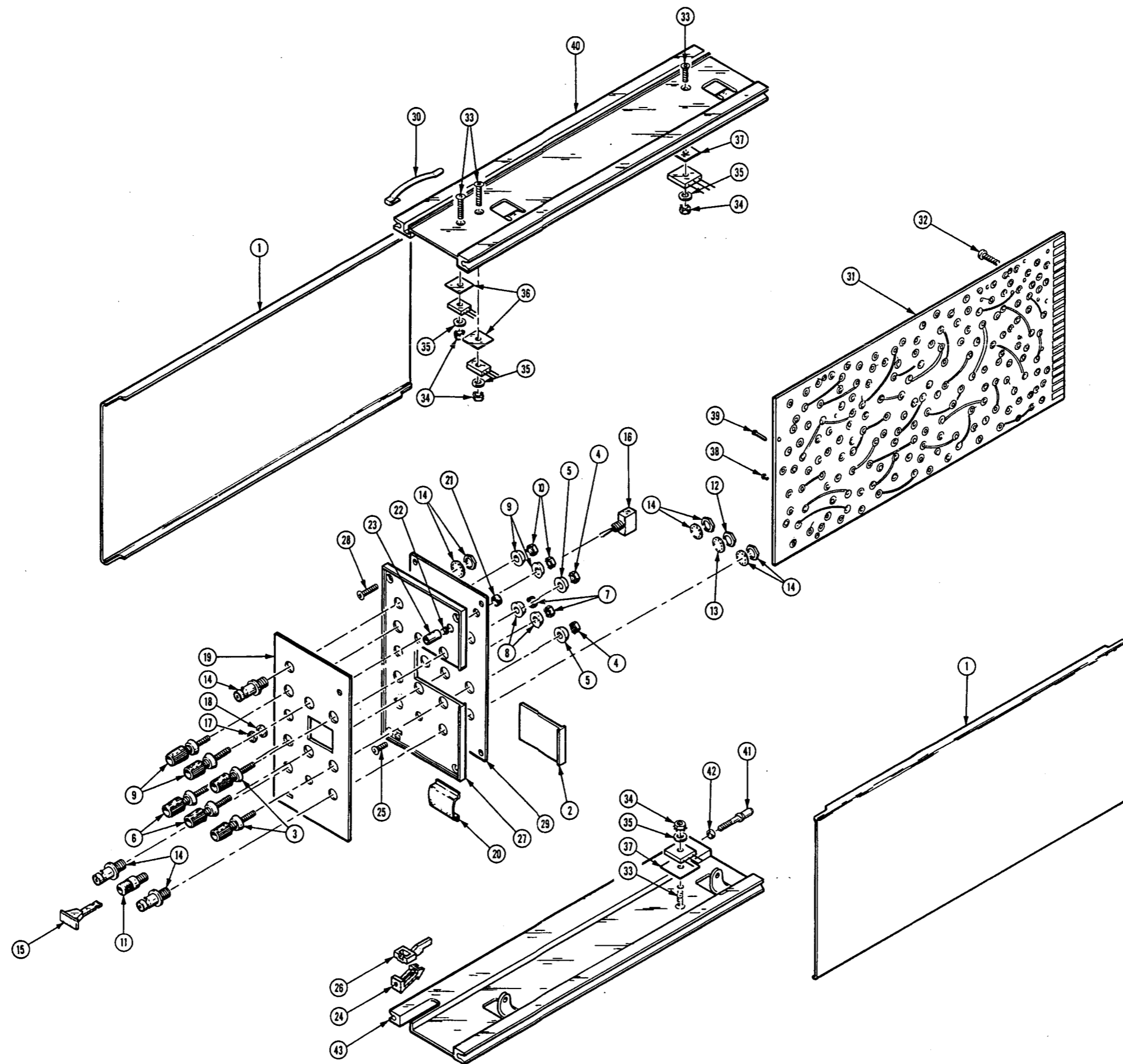

Fig. 3-1. Location of Power Supply and Offset Null adjustments and test points.



MAINTENANCE AND INTERFACING INFORMATION

Preventive Maintenance

There are no special preventive maintenance procedures that apply to the AM 501. Refer to the power module instruction manual for general preventive maintenance procedures and instructions.

Corrective Maintenance

Refer to the power module instruction manual for general corrective maintenance procedures and instructions.

Troubleshooting

Use the Performance Check, Adjustment Procedure, and Circuit Description as aids to locate trouble in the event of equipment failure. The test equipment listed in the Performance Check and Adjustment Procedure will prove useful in troubleshooting the AM 501.

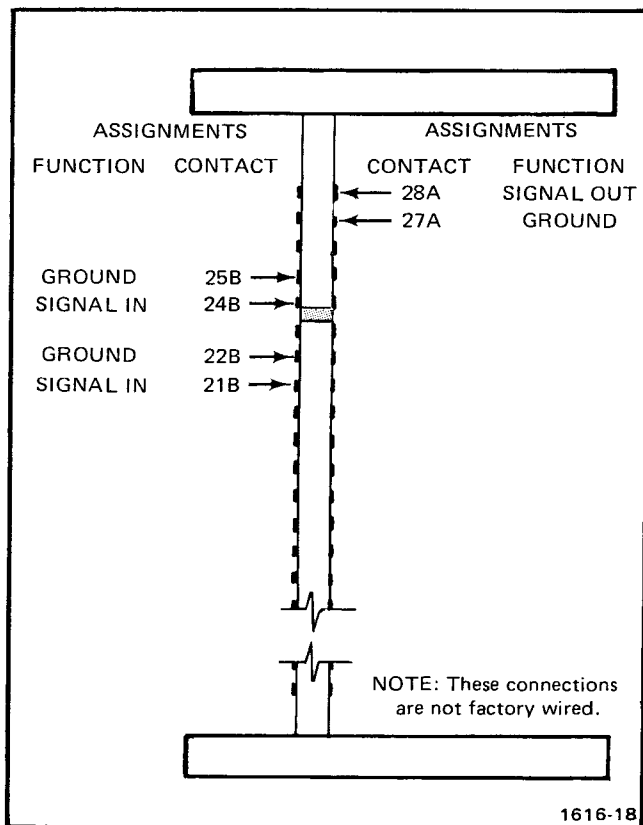

Fig. 4-1. Input-Output assignments for plug-in rear interface connector contacts.

Input, Output, and Feedback Connections

Make connections to the operational amplifier through the front-panel binding posts, the bnc connectors, or the rear interface connector. The rear interface connections are not factory wired. See Fig. 4-1 for suggested pin numbers and functions. Pads are provided on the circuit board for the pins shown.

A barrier inserted between pins 23 and 24 in the power module will allow the AM 501, and plug-ins compatible with it, to be inserted in that compartment. See the power module manual for more information.

Fig. 4-2 shows pad layouts for internal component connections. Any combination of resistors, capacitors or other components may be soldered to the pads as required. Jumper from the Input, Output, and Ground connections, labeled on the board, to the appropriate pads. If necessary, remove the wires to the front-panel connections, and re-connect them to the pads.

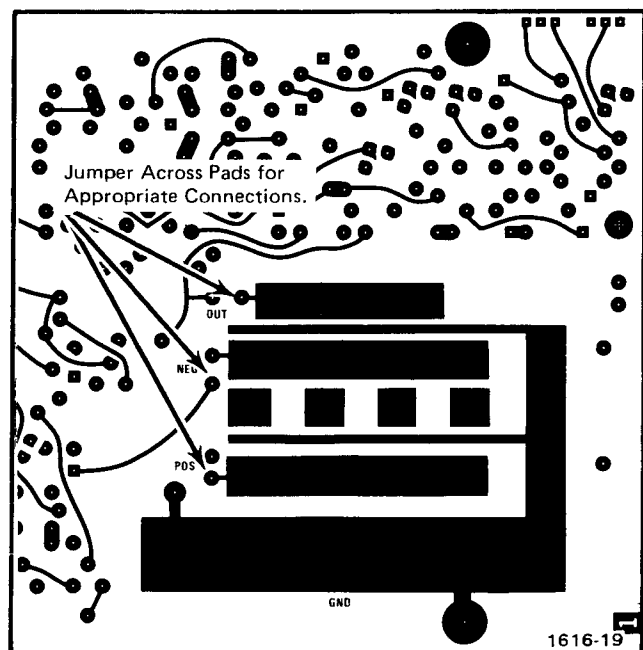

Fig. 4-2. Pad layouts for internal connections.

Maintenance and Interfacing Information—AM 501

If more than a foot or two of coaxial cable is used at the output, an isolation resistor equal to the cable impedance should be connected between the amplifier OUTPUT terminal and the center conductor of the coaxial cable to prevent ringing. This resistor may conveniently be connected between J175 (lower OUTPUT binding post) and J176 (OUTPUT bnc connector).

A transparent window with removable information slide is provided for noting the connections made to the AM 501. To remove the slide, grasp the sectioned sub-panel, on the right side of the instrument and pull. Attach a gummed label to the slide and draw on the label the connections made.

Optional Bandwidth Limiting

The AM 501 bandwidth can be limited by adding a capacitor in parallel with C118. If the capacitor is added, the performance check will have to be altered for the new bandwidth limit.

REPACKAGING FOR SHIPMENT

If the Tektronix instrument is to be shipped to a Tektronix Service Center for service or repair, attach a tag showing: owner (with address) and the name of an individual at your firm that can be contacted. Include complete instrument serial number and a description of the service required.

Save and re-use the package in which your instrument was shipped. If the original packaging is unfit for use or not available, repackage the instrument as follows:

Surround the instrument with polyethylene sheeting to protect the finish of the instrument. Obtain a carton of corrugated cardboard of the correct carton strength and having inside dimensions of no less than six inches more than the instrument dimensions. Cushion the instrument by tightly packing three inches of dunnage or urethane foam between carton and instrument, on all sides. Seal carton with shipping tape or industrial stapler.

The carton test strength for your instrument is 200 pounds.

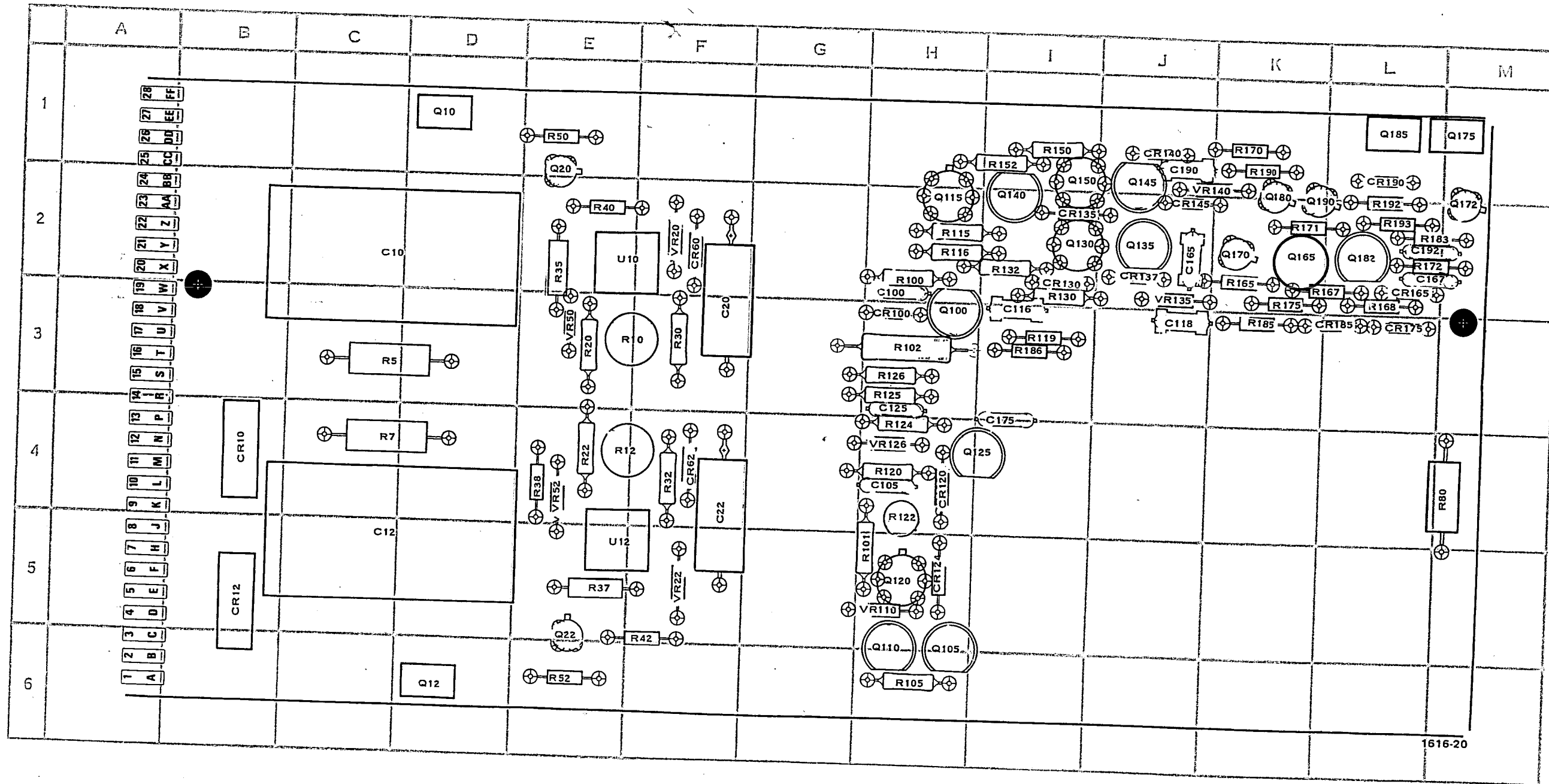

1616-20

A1 MAIN CIRCUIT BOARD

CKT NO	GRID LOC	CKT NO	GRID LOC	CKT NO	GRID LOC	CKT NO	GRID LOC	CKT NO	GRID LOC	CKT NO	GRID LOC	CKT NO	GRID LOC	CKT NO	GRID LOC	CKT NO	GRID LOC
C10	C2	C175	I4	CR135	I2	Q22	E5	Q165	K2	R12	E4	R80	M4	R126	H3	R183	L2
C12	C5	C190	J1	CR137	J2	Q100	H3	Q170	K2	R20	E3	R100	H2	R130	I2	R185	K3
C20	F3	C192	L2	CR140	J1	Q105	H6	Q172	M2	R22	E4	R101	H5	R132	I2	R186	I3
C22	F4			CR145	J2	Q110	H6	Q175	M1	R30	F3	R102	H3	R150	I1	R188	L2
C100	H2	CR10	B4	CR165	L2	Q115	H2	Q180	K2	R32	F4	R105	H6	R152	I1	R189	K1
C105	H4	CR12	B5	CR175	L3	Q120	H5	Q182	L2	R35	E2	R115	H2	R165	K2	R192	L2
C116	I3	CR60	F2	CR185	L3	Q125	I4	Q185	L1	R37	E5	R116	H2	R167	L2	R193	L2
C118	J3	CR62	F4	CR190	L1	Q130	I2	Q190	K2	R38	E4	R119	I3	R170	K1	U10	E2
C125	H3	CR100	H3			Q135	J2			R40	E2	R120	H4	R171	K2	U12	E5
C165	J2	CR120	H4	Q10	D1	Q140	I2			R42	F6	R122	H4	R172	L2	VR20	F2
C167	L2	CR124	H5	Q12	D6	Q145	J1			R50	E1	R124	H4	R175	K2	VR22	F5
C167	L2	CR130	I2	Q20	E1	Q150	I1			R52	E6	R125	H3				

DIAGRAMS AND CIRCUIT BOARD ILLUSTRATIONS

Symbols and Reference Designators

Electrical components shown on the diagrams are in the following units unless noted otherwise:

- Capacitors = Values one or greater are in picofarads (pF).
Values less than one are in microfarads (μF).
- Resistors = Ohms (Ω).

Graphic symbols and class designation letters are based on ANSI Standard Y32.2-1975.

Logic symbology is based on ANSI Y32.14-1973 in terms of positive logic. Logic symbols depict the logic function performed and may differ from the manufacturer's data.

The overline on a signal name indicates that the signal performs its intended function when it goes to the low state.

Abbreviations are based on ANSI Y1.1-1972.

Other ANSI standards that are used in the preparation of diagrams by Tektronix, Inc. are:

- Y14.15, 1966 Drafting Practices.
- Y14.2, 1973 Line Conventions and Lettering.
- Y10.5, 1968 Letter Symbols for Quantities Used in Electrical Science and Electrical Engineering.

The following prefix letters are used as reference designators to identify components or assemblies on the diagrams.

A	Assembly, separable or repairable (circuit board, etc)	H	Heat dissipating device (heat sink, heat radiator, etc)	S	Switch or contactor
AT	Attenuator, fixed or variable	HR	Heater	T	Transformer
B	Motor	HY	Hybrid circuit	TC	Thermocouple
BT	Battery	J	Connector, stationary portion	TP	Test point
C	Capacitor, fixed or variable	K	Relay	U	Assembly, inseparable or non-repairable (integrated circuit, etc.)
CB	Circuit breaker	L	Inductor, fixed or variable	V	Electron tube
CR	Diode, signal or rectifier	M	Meter	VR	Voltage regulator (zener diode, etc.)
DL	Delay line	P	Connector, movable portion	W	Wirestrap or cable
DS	Indicating device (lamp)	Q	Transistor or silicon-controlled rectifier	Y	Crystal
E	Spark Gap, Ferrite bead	R	Resistor, fixed or variable	Z	Phase shifter
F	Fuse	RT	Thermistor		
FL	Filter				

The following special symbols may appear on the diagrams:

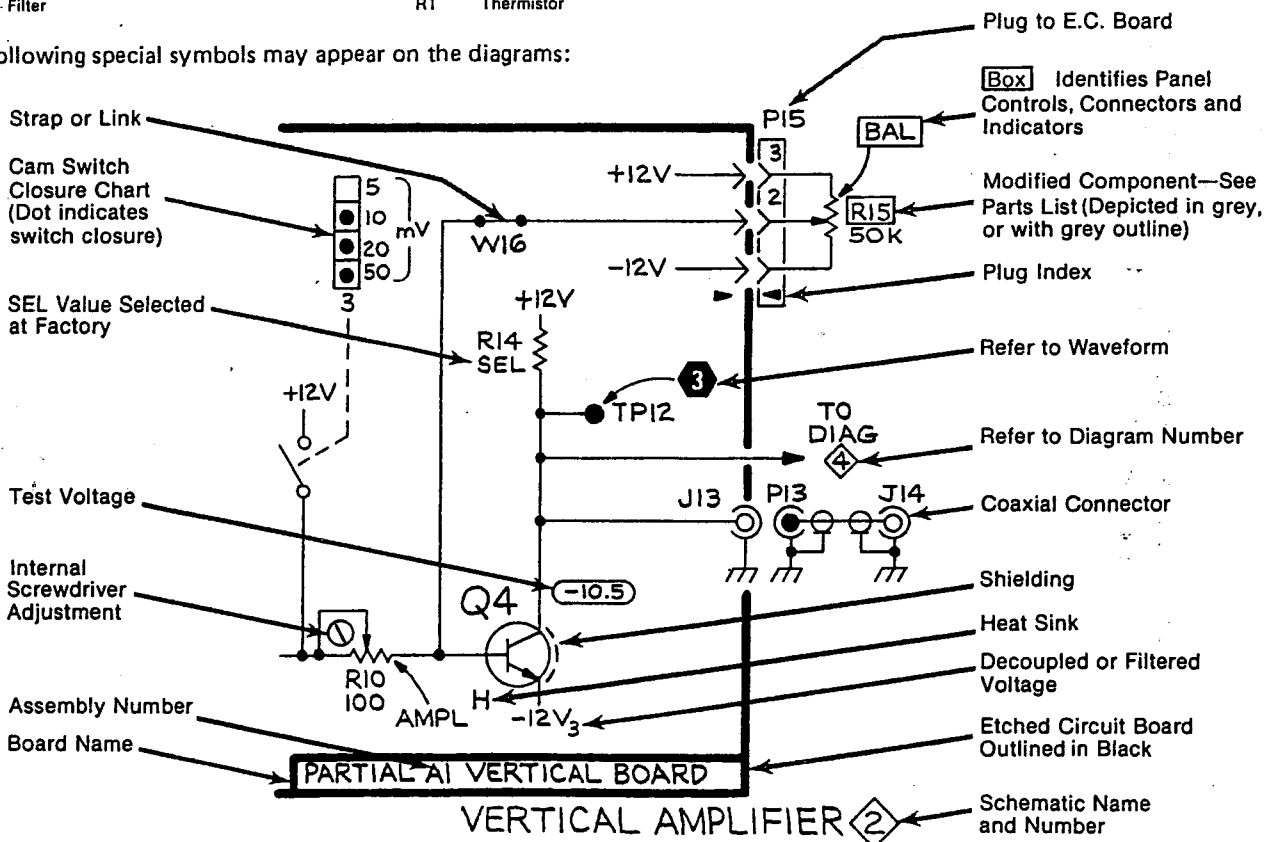

CIRCUIT DESCRIPTION

Introduction

This section of the manual contains a description of the circuitry used in the AM 501 Operational Amplifier. Individual descriptions are separated into the following parts: General, Input Amplifier, Output Amplifier, and Power Supply. Refer to the appropriate diagrams in the Diagrams section of this manual while reading the circuit description.

General

The AM 501 is a feedback amplifier having low output impedance, high overall gain, high output voltage and current capabilities and excellent stability.

The high gain section of the amplifier consists of the input FET and current sources, and the output current sources. The output current sources serve as high impedance loads for the FET. The gain is $G_m R_o$, where G_m is the transconductance of the input FET and R_o is the impedance of the feedback amplifiers used as signal current sources at the output.

The output stage is a unity-gain amplifier having a very high input impedance and low output impedance. The output stage is capable of ± 40 volts at approximately 50 mA.

Input Amplifier

The input FET uses a conventional current source, Q125, that provides a constant current, determined by the divider R101, R102, R126 and VR126.

The source-to-drain voltage of the input FET is maintained at a constant value by VR110 and Q110, so that even though the common-mode input level may change, the FET characteristics remain constant.

CR100 and R100 provide impedance at the drain of Q120A (plus input) equivalent to the impedance at the drain of Q120B (minus input).

Q105 is the current source for VR110. Q125 provides about 6 mA and Q105 needs about 2 mA. This leaves about 4 mA for Q120. Thus, when Q120 is balanced, 2 mA flows through each side of Q120.

VR126, R101, R102, R105, R125, and R126 set a relationship between current sources Q105 and Q125 so that any current change in one is matched by an equal change in the other. This keeps the total current in Q120 constant, and thus maintains amplifier stability with temperature and supply voltage variations.

The 2 mA flowing through Q120A also flows through common-base stage Q100, providing 2 mA to the controlled signal current source, Q130 and Q135.

The same condition exists in the Q115-Q140 side of the amplifier, which supplies 2 mA through Q140 to Q145 and Q150.

Differences in characteristics of the active components are balanced out using the Offset Null control, R122.

Q130 and Q135, and their counterparts, Q145 and Q150, act as signal current sources. Any voltage change at the base of Q135 causes equal current changes in Q130A and Q130B, since they are matched transistors. The same is true for Q145, Q150A, and Q150B. Although the current through Q135 is fairly insensitive to collector voltage, slightly more current will flow through Q135 and Q130B when Q135's collector is more negative. This increased current passing through Q130B causes equally increased current flow in Q130A, making its collector go more positive and reducing the additional current through Q135. Again, the identical action takes place in Q145 and Q150, only the polarities are different. Thus, for a given signal current change at the base of Q135 and Q145, the output current at the collectors of Q135 and Q145 changes proportionally. This current change is nearly independent of the voltage at the collectors of Q135 and Q145. The drains of the input FETs see an effective load impedance of approximately 10 M Ω . This configuration also provides a single voltage amplification point, and a single RC amplitude vs. frequency rolloff characteristic. These factors are necessary to prevent oscillation when using 100% feedback.

CR130 and CR135 (CR140-CR145) prevent saturation of Q135 (Q145) when full differential voltage is applied at the input.

Circuit Description—AM 501

VR135 and VR140 limit the voltage at the common output point, preventing saturation in the output amplifier. CR137 is a voltage-dropping diode used to compensate for inequality in junction drops from side to side in the output amplifier.

No harm can be done to the input, even if the input drive is maximum (+40 V and -40 V). The range of the amplifier will have been exceeded (it will be locked up at one end), but as the gate-to-drain breakdown of Q120 is reached, current limiting diode CR120 (CR124) limits the input current to 1 mA, protecting the FET. Below this point, CR120 (CR124) behaves as a low value resistor, approximately 1 to 2 k Ω .

C118 and R119 prevent oscillation at the higher frequency limits. C116 improves the slewing rate during high common-mode voltage swings. The bandwidth may be reduced, if desired, by the addition of capacitance at Points 1 and 2. See Fig. 3-1 for location.

Output Amplifier

The Output Amplifier is a unity-gain voltage-follower impedance-transforming amplifier.

Q170 is an emitter follower, having a current source from Q165, feeding two successive emitter followers, Q172 and Q175.

Q180 is an emitter follower, having a current source from Q190, feeding a unity-gain feedback amplifier, Q182 and Q185.

The algebraic sum of the diode and base-emitter drops around the loop, starting at the collector of Q185 (the emitter of Q182) and progressing clockwise to the emitter of Q175, is slightly greater than zero. These voltage drops are impressed across R175 and R185 to fix the standing current in the output transistors.

With the input FET gates tied together, the output voltage (at the junction of R175-R185) is zero.

R168 and R193 are part of a current-limiting circuit. As the load current increases to a value near the limit, the drop across R168 causes CR165 to turn on, taking emitter current from the current source, Q165. When the load

current reaches its limit, enough current is diverted from Q165 to shut Q170 off and prevent the output from moving any further positive.

The same current limiting occurs in the other direction (negative swing at the output). R193 senses the load current, CR190 turns on, taking current from Q190 and preventing the negative driving signal from driving the output too far negative.

CR175 and CR185 prevent Q170 and Q180 from reaching base-emitter reverse breakdown during conditions of output overload or short circuit.

CR175 and R186 prevent oscillation when the output is capacitively loaded.

Power Supply

CR10 (a bridge) rectifies 25 V ac from the power module. This voltage is added to the +33.5 V dc from the power module to provide raw dc for the regulated +49 V dc. The +33.5 V is applied to pin 7 (V_{cc}) of the operational amplifier, U10. The plus input is referenced by VR50. The output voltage is sensed through R30 to the minus input of U10. VR20 allows U10 to operate near ground while controlling the current through Q10. R10 sets the output voltage. If the output voltage decreases, pin 2 of U10 goes negative, causing pin 6 to go positive. This action increases the current flow through Q10 to the load, bringing the voltage across the load to its original value. If the current through Q10 becomes excessive, the voltage dropped across R50 will turn Q20 on. As the current increases, Q20 will finally turn Q10 off, thus limiting the current. CR60 serves as a protective diode preventing the positive power bus from going below ground.

The -49 V supply operates nearly the same as the +49 V supply. 25 V ac is bridge rectified by CR12 and added to -33.5 V dc from the power module. VR52 references the negative input of U20, an operational amplifier. The -49 V is adjusted by R12, connected to the plus input of U20. If the load on the -49 V supply increases, the voltage will go more positive. This causes pin 3 of U20 to move in the positive direction through R32 and R12. Pin 6 of U20 goes positive, increasing conduction in Q12, restoring the -49 V and causing equilibrium at pins 2 and 3 of U20. If the load on the -49 V supply increases to the point of causing the voltage drop across R52 to turn Q22 on, pin 3 of U20 will go negative causing the base of Q12 to go negative. This reduces the current to the load to within safe limits.

VOLTAGE CONDITIONS

WARNING

Dangerous potentials exist at several points throughout this instrument. When the instrument is operated with the covers removed, do not touch exposed connections or components. Some transistors have voltages present on their cases. Disconnect the power source before replacing parts.

The voltages shown on diagrams 1 and 2 were taken with the power module PWR switch in the on position. No external load was connected to the binding post output terminals.

Voltage Conditions. The voltages shown on the diagram were obtained using a digital multimeter with a 10 m Ω input impedance (TEKTRONIX DM 501 Digital Multimeter or TEKTRONIX 7D13 Digital Multimeter used with readout equipped, 7000-series oscilloscope).

Voltages on the diagrams are not absolute and may vary between instruments because of component tolerances, internal calibration, or front-panel settings.

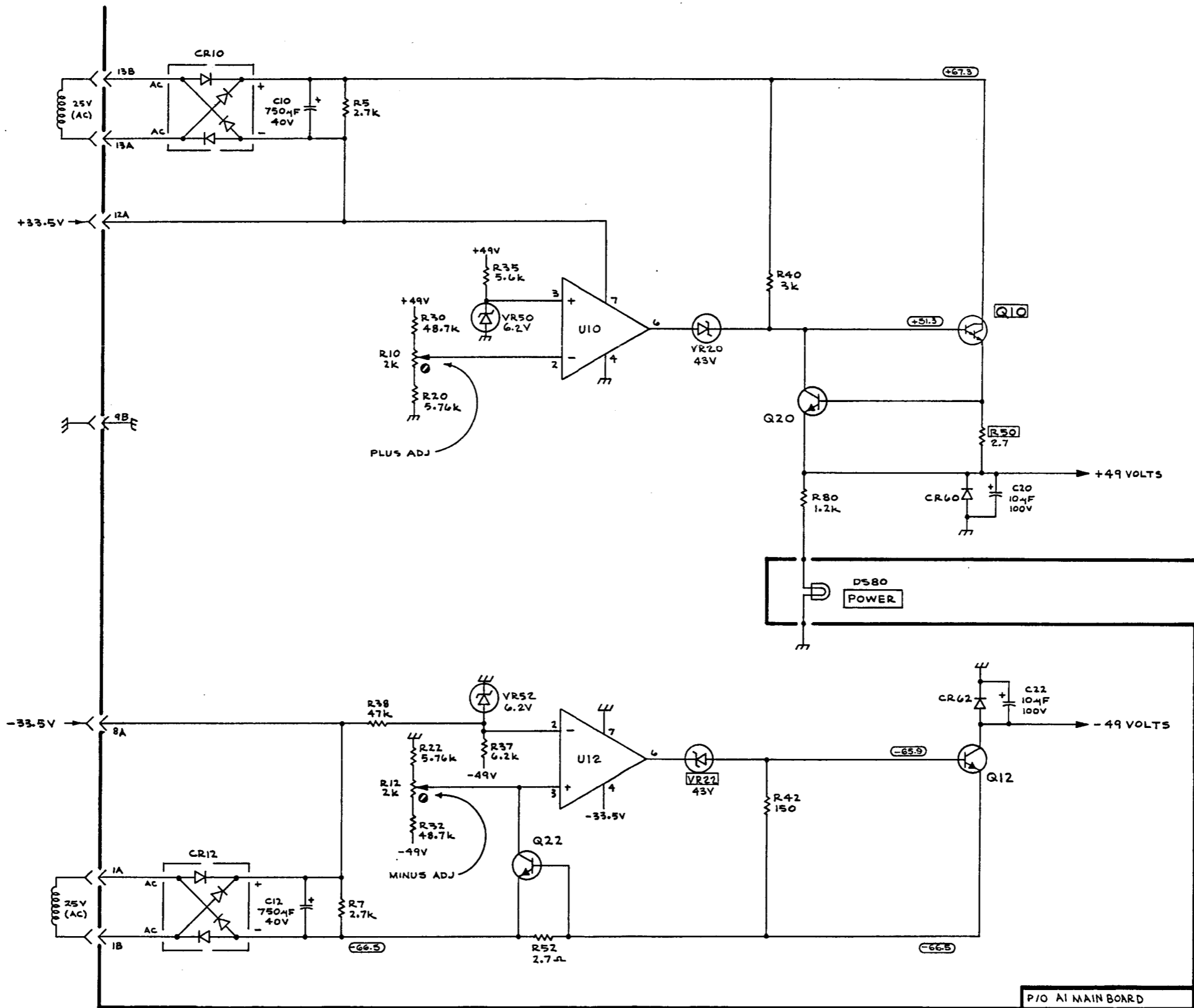

SEE PARTS LIST FOR EARLIER VALUES AND SERIAL NUMBER RANGES OF PARTS OUTLINED OR DEPICTED IN GREY.

VOLTAGE CONDITIONS

WARNING

Dangerous potentials exist at several points throughout this instrument. When the instrument is operated with the covers removed, do not touch exposed connections or components. Some transistors have voltages present on their cases. Disconnect the power source before replacing parts.

The voltages shown on diagrams 1 and 2 were taken with the power module PWR switch in the on position. No external load was connected to the binding post output terminals.

Voltage Conditions. The voltages shown on the diagram were obtained using a digital multimeter with a 10 m Ω input impedance (TEKTRONIX DM 501 Digital Multimeter or TEKTRONIX 7D13 Digital Multimeter used with readout equipped, 7000-series oscilloscope).

Voltages on the diagrams are not absolute and may vary between instruments because of component tolerances, internal calibration, or front-panel settings.

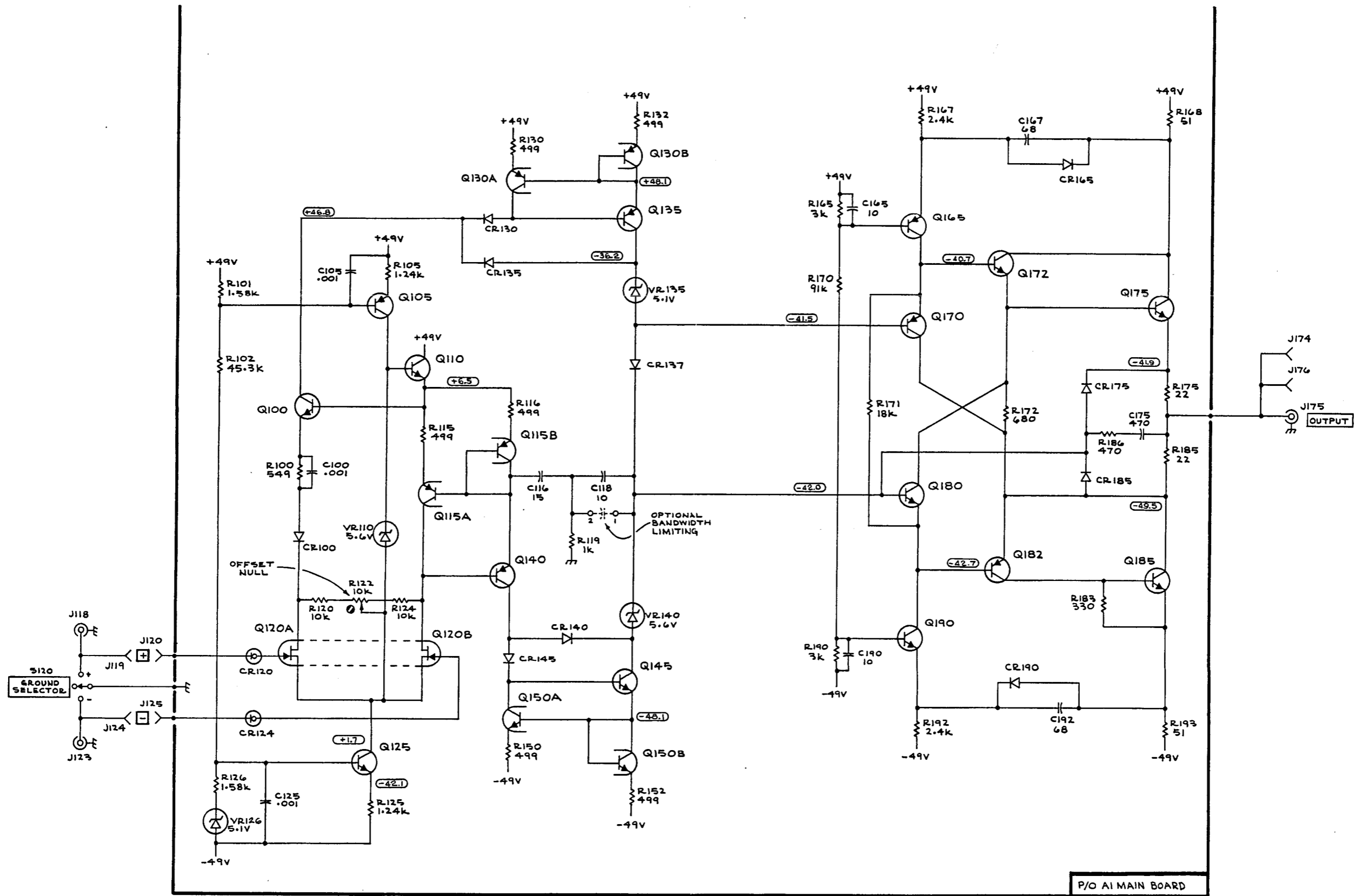

OPTIONS

(No options are available at this time)

REPLACEABLE ELECTRICAL PARTS

PARTS ORDERING INFORMATION

Replacement parts are available from or through your local Tektronix, Inc. Field Office or representative.

Changes to Tektronix instruments are sometimes made to accommodate improved components as they become available, and to give you the benefit of the latest circuit improvements developed in our engineering department. It is therefore important, when ordering parts, to include the following information in your order: Part number, instrument type or number, serial number, and modification number if applicable.

If a part you have ordered has been replaced with a new or improved part, your local Tektronix, Inc. Field Office or representative will contact you concerning any change in part number.

Change information, if any, is located at the rear of this manual.

SPECIAL NOTES AND SYMBOLS

X000 Part first added at this serial number
00X Part removed after this serial number

ITEM NAME

In the Parts List, an Item Name is separated from the description by a colon (:). Because of space limitations, an Item Name may sometimes appear as incomplete. For further Item Name identification, the U.S. Federal Cataloging Handbook H6-1 can be utilized where possible.

ABBREVIATIONS

ACTR	ACTUATOR	PLSTC	PLASTIC
ASSY	ASSEMBLY	QTZ	QUARTZ
CAP	CAPACITOR	RECP	RECEPTACLE
CER	CERAMIC	RES	RESISTOR
CKT	CIRCUIT	RF	RADIO FREQUENCY
COMP	COMPOSITION	SEL	SELECTED
CONN	CONNECTOR	SEMICOND	SEMICONDUCTOR
ELCTLT	ELECTROLYTIC	SENS	SENSITIVE
ELEC	ELECTRICAL	VAR	VARIABLE
INCAND	INCANDESCENT	WW	WIREWOUND
LED	LIGHT EMITTING DIODE	XFMR	TRANSFORMER
NONWIR	NON WIREWOUND	XTAL	CRYSTAL

Replaceable Electrical Parts—AM 501

CROSS INDEX—MFR. CODE NUMBER TO MANUFACTURER

Mfr. Code	Manufacturer	Address	City, State, Zip
01121	ALLEN-BRADLEY COMPANY	1201 2ND STREET SOUTH	MILWAUKEE, WI 53204
01295	TEXAS INSTRUMENTS, INC., SEMICONDUCTOR GROUP	P O BOX 5012, 13500 N CENTRAL EXPRESSWAY	DALLAS, TX 75222
04713	MOTOROLA, INC., SEMICONDUCTOR PROD. DIV.	5005 E MCDOWELL RD, PO BOX 20923	PHOENIX, AZ 85036
07263	FAIRCHILD SEMICONDUCTOR, A DIV. OF FAIRCHILD CAMERA AND INSTRUMENT CORP.	464 ELLIS STREET	MOUNTAIN VIEW, CA 94042
09353	C AND K COMPONENTS, INC.	103 MORSE STREET	WATERTOWN, MA 02172
12954	SIEMENS CORPORATION, COMPONENTS GROUP	8700 E THOMAS RD, P O BOX 1390	SCOTTSDALE, AZ 85252
13511	AMPHENOL CARDRE DIV., BUNKER RAMO CORP.		LOS GATOS, CA 95030
56289	SPRAGUE ELECTRIC CO.		NORTH ADAMS, MA 01247
58474	SUPERIOR ELECTRIC CO.	383 MIDDLE ST.	BRISTOL, CT 06010
71744	CHICAGO MINIATURE LAMP WORKS	4433 RAVENSWOOD AVE.	CHICAGO, IL 60640
72982	ERIE TECHNOLOGICAL PRODUCTS, INC.	644 W. 12TH ST.	ERIE, PA 16512
73138	BECKMAN INSTRUMENTS, INC., HELIPOT DIV.	2500 HARBOR BLVD.	FULLERTON, CA 92634
75042	TRW ELECTRONIC COMPONENTS, IRC FIXED RESISTORS, PHILADELPHIA DIVISION	401 N. BROAD ST.	PHILADELPHIA, PA 19108
80009	TEKTRONIX, INC.	P O BOX 500	BEAVERTON, OR 97077
91637	DALE ELECTRONICS, INC.	P. O. BOX 609	COLUMBUS, NE 68601

Ckt No.	Tektronix Part No.	Serial/Model No. Eff	Discont	Name & Description	Mfr Code	Mfr Part Number
A1	670-2958-00	B010100	B032019	CKT BOARD ASSY:MAIN	80009	670-2958-00
A1	670-2958-01	B032020		CKT BOARD ASSY:MAIN	80009	670-2958-01
C10	290-0324-00			CAP., FXD, ELCTLT: 750UF, +75-10%, 40V	56289	D46454
C12	290-0324-00			CAP., FXD, ELCTLT: 750UF, +75-10%, 40V	56289	D46454
C20	290-0194-00			CAP., FXD, ELCTLT: 10UF, +50-10%, 100V	56289	30D106F100DC4
C22	290-0194-00			CAP., FXD, ELCTLT: 10UF, +50-10%, 100V	56289	30D106F100DC4
C100	283-0000-00			CAP., FXD, CER DI: 0.001UF, +100-0%, 500V	72982	831-516E102P
C105	283-0000-00			CAP., FXD, CER DI: 0.001UF, +100-0%, 500V	72982	831-516E102P
C116	281-0628-00			CAP., FXD, CER DI: 15PF, 5%, 500V	72982	301-000C0G0150J
C118	281-0504-00			CAP., FXD, CER DI: 10PF, +/-1PF, 500V	72982	301-055C0G0100F
C125	283-0000-00			CAP., FXD, CER DI: 0.001UF, +100-0%, 500V	72982	831-516E102P
C165	281-0504-00			CAP., FXD, CER DI: 10PF, +/-1PF, 500V	72982	301-055C0G0100F
C167	281-0549-00			CAP., FXD, CER DI: 68PF, 10%, 500V	72982	301-000U2J0680K
C175	283-0032-00			CAP., FXD, CER DI: 470PF, 5%, 500V	72982	0831085Z5E00471J
C190	281-0504-00			CAP., FXD, CER DI: 10PF, +/-1PF, 500V	72982	301-055C0G0100F
C192	281-0549-00			CAP., FXD, CER DI: 68PF, 10%, 500V	72982	301-000U2J0680K
CR10	152-0488-00			SEMICONV DEVICE: SILICON, 200V, 1500MA	80009	152-0488-00
CR12	152-0488-00			SEMICONV DEVICE: SILICON, 200V, 1500MA	80009	152-0488-00
CR60	152-0107-00			SEMICONV DEVICE: SILICON, 400V, 400MA	80009	152-0107-00
CR62	152-0107-00			SEMICONV DEVICE: SILICON, 400V, 400MA	80009	152-0107-00
CR100	152-0141-02			SEMICONV DEVICE: SILICON, 30V, 50NA	01295	1N4152R
CR120	152-0460-00			SEMICONV DEVICE: SILICON, 25V, 1MA	04713	1N5299
CR124	152-0460-00			SEMICONV DEVICE: SILICON, 25V, 1MA	04713	1N5299
CR130	152-0141-02			SEMICONV DEVICE: SILICON, 30V, 50NA	01295	1N4152R
CR135	152-0061-00			SEMICONV DEVICE: SILICON, 175V, 100MA	07263	FDH2161
CR137	152-0141-02			SEMICONV DEVICE: SILICON, 30V, 50NA	01295	1N4152R
CR140	152-0061-00			SEMICONV DEVICE: SILICON, 175V, 100MA	07263	FDH2161
CR145	152-0141-02			SEMICONV DEVICE: SILICON, 30V, 50NA	01295	1N4152R
CR165	152-0141-02			SEMICONV DEVICE: SILICON, 30V, 50NA	01295	1N4152R
CR175	152-0141-02			SEMICONV DEVICE: SILICON, 30V, 50NA	01295	1N4152R
CR185	152-0141-02			SEMICONV DEVICE: SILICON, 30V, 50NA	01295	1N4152R
CR190	152-0141-02			SEMICONV DEVICE: SILICON, 30V, 50NA	01295	1N4152R
DS80	150-0109-00			LAMP, INCAND: 18V, 26MA	71744	CM7220
J118	131-0955-00			CONNECTOR, RCPT, : BNC, FEMALE, W/HARDWARE	13511	31-279
J119	129-0064-01			POST, BDG, ELEC: RED, 5-WAY MINIATURE	58474	BB10167G2BX
J120	129-0064-01			POST, BDG, ELEC: RED, 5-WAY MINIATURE	58474	BB10167G2BX
J123	131-0955-00			CONNECTOR, RCPT, : BNC, FEMALE, W/HARDWARE	13511	31-279
J124	129-0064-02			POST, BDG, ELEC: WHITE, 5-WAY, MINIATURE	58474	DF21WTC
J125	129-0064-02			POST, BDG, ELEC: WHITE, 5-WAY, MINIATURE	58474	DF21WTC
J174	129-0064-00			POST, BDG, ELEC: CHARCOAL, 5-WAY MINIATURE	58474	BINP BB10167G13T
J175	131-0955-00			CONNECTOR, RCPT, : BNC, FEMALE, W/HARDWARE	13511	31-279
J176	129-0064-00			POST, BDG, ELEC: CHARCOAL, 5-WAY MINIATURE	58474	BINP BB10167G13T
Q10	151-0436-00	B010100	B032019	TRANSISTOR: SILICON, NPN	80009	151-0436-00
Q10	151-0415-00	B032020		TRANSISTOR: SILICON, NPN	04713	MJE1102
Q12	151-0436-00			TRANSISTOR: SILICON, NPN	80009	151-0436-00
Q20	151-0347-00			TRANSISTOR: SILICON, NPN	80009	151-0347-00
Q22	151-0347-00			TRANSISTOR: SILICON, NPN	80009	151-0347-00
Q100	151-0279-00			TRANSISTOR: SILICON, NPN	80009	151-0279-00
Q105	151-0350-00			TRANSISTOR: SILICON, PNP	80009	151-0350-00
Q110	151-0279-00			TRANSISTOR: SILICON, NPN	80009	151-0279-00
Q115A, B	151-0261-00			TRANSISTOR: SILICON, PNP, DUAL	80009	151-0261-00
Q120A, B	151-1010-00			TRANSISTOR: SILICON, JFE, DUAL	80009	151-1010-00
Q125	151-0279-00			TRANSISTOR: SILICON, NPN	80009	151-0279-00
Q130A, B	151-0261-00			TRANSISTOR: SILICON, PNP, DUAL	80009	151-0261-00

Replaceable Electrical Parts—AM 501

Ckt No.	Tektronix Part No.	Serial/Model No. Eff	Dscont	Name & Description	Mfr Code	Mfr Part Number
Q135	151-0228-00			TRANSISTOR:SILICON,PNP,SEL FROM 2N4888	80009	151-0228-00
Q140	151-0228-00			TRANSISTOR:SILICON,PNP,SEL FROM 2N4888	80009	151-0228-00
Q145	151-0279-00			TRANSISTOR:SILICON,NPN	80009	151-0279-00
Q150A,B	151-0232-00			TRANSISTOR:SILICON,NPN,DUAL	80009	151-0232-00
Q165	151-0350-00			TRANSISTOR:SILICON,PNP	80009	151-0350-00
Q170	151-0188-00			TRANSISTOR:SILICON,PNP	80009	151-0188-00
Q172	151-0347-00			TRANSISTOR:SILICON,NPN	80009	151-0347-00
Q175	151-0311-01			TRANSISTOR:SILICON,NPN	80009	151-0311-01
Q180	151-0190-00			TRANSISTOR:SILICON,NPN	07263	S032677
Q182	151-0350-00			TRANSISTOR:SILICON,PNP	80009	151-0350-00
Q185	151-0311-01			TRANSISTOR:SILICON,NPN	80009	151-0311-01
Q190	151-0347-00			TRANSISTOR:SILICON,NPN	80009	151-0347-00
R5	304-0272-00			RES.,FXD,CMPSN:2.7 OHM,10%,1W	01121	GB2721
R7	304-0272-00			RES.,FXD,CMPSN:2.7 OHM,10%,1W	01121	GB2721
R10	311-1562-00			RES.,VAR,NONWIR:2K OHM,20%,0.50W	73138	91A R2K
R12	311-1562-00			RES.,VAR,NONWIR:2K OHM,20%,0.50W	73138	91A R2K
R20	321-0266-00			RES.,FXD,FILM:5.76K OHM,1%,0.125W	91637	MFF1816G57600F
R22	321-0266-00			RES.,FXD,FILM:5.76K OHM,1%,0.125W	91637	MFF1816G57600F
R30	321-0355-00			RES.,FXD,FILM:48.7K OHM,1%,0.125W	91637	MFF1816G48701F
R32	321-0355-00			RES.,FXD,FILM:48.7K OHM,1%,0.125W	91637	MFF1816G48701F
R35	301-0562-00			RES.,FXD,CMPSN:5.6K OHM,5%,0.50W	01121	EB5625
R37	301-0622-00			RES.,FXD,CMPSN:6.2K OHM,5%,0.50W	01121	EB6225
R38	315-0473-00			RES.,FXD,CMPSN:47K OHM,5%,0.25W	01121	CB4735
R40	315-0302-00			RES.,FXD,CMPSN:3K OHM,5%,0.25W	01121	CB3025
R42	315-0151-00			RES.,FXD,CMPSN:150 OHM,5%,0.25W	01121	CB1515
R50	307-0107-00	B010100	B032019	RES.,FXD,CMPSN:5.6 OHM,5%,0.25W	01121	CB56G5
R50	307-0103-00	B032020		RES.,FXD,CMPSN:2.7 OHM,5%,0.25W	01121	CB27G5
R52	307-0103-00			RES.,FXD,CMPSN:2.7 OHM,5%,0.25W	01121	CB27G5
R80	303-0122-00			RES.,FXD,CMPSN:1.2K OHM,5%,1W	01121	GB1225
R100	321-0168-00			RES.,FXD,FILM:549 OHM,1%,0.125W	91637	MFF1816G549ROF
R101	321-0212-00			RES.,FXD,FILM:1.58K OHM,1%,0.125W	91637	MFF1816G15800F
R102	323-0352-00			RES.,FXD,FILM:45.3K OHM,1%,0.50W	75042	CECTO-4532F
R105	321-0202-00			RES.,FXD,FILM:1.24K OHM,1%,0.125W	91637	MFF1816G12400F
R115	321-0164-00			RES.,FXD,FILM:499 OHM,1%,0.125W	91637	MFF1816G499ROF
R116	321-0164-00			RES.,FXD,FILM:499 OHM,1%,0.125W	91637	MFF1816G499ROF
R119	316-0102-00	B010100	B032059	RES.,FXD,CMPSN:1K OHM,10%,0.25W	01121	CB1021
R119	315-0102-00	B032060		RES.,FXD,CMPSN:1K OHM,5%,0.25W	01121	CB1025
R120	321-0289-00			RES.,FXD,FILM:10K OHM,1%,0.125W	91637	MFF1816G10001F
R122	311-0607-00			RES.,VAR,NONWIR:10K OHM,10%,0.50W	73138	82P-59-4-103K
R124	321-0289-00			RES.,FXD,FILM:10K OHM,1%,0.125W	91637	MFF1816G10001F
R125	321-0202-00			RES.,FXD,FILM:1.24K OHM,1%,0.125W	91637	MFF1816G12400F
R126	321-0212-00			RES.,FXD,FILM:1.58K OHM,1%,0.125W	91637	MFF1816G15800F
R130	321-0164-00			RES.,FXD,FILM:499 OHM,1%,0.125W	91637	MFF1816G499ROF
R132	321-0164-00			RES.,FXD,FILM:499 OHM,1%,0.125W	91637	MFF1816G499ROF
R150	321-0164-00			RES.,FXD,FILM:499 OHM,1%,0.125W	91637	MFF1816G499ROF
R152	321-0164-00			RES.,FXD,FILM:499 OHM,1%,0.125W	91637	MFF1816G499ROF
R165	315-0302-00			RES.,FXD,CMPSN:3K OHM,5%,0.25W	01121	CB3025
R167	315-0242-00			RES.,FXD,CMPSN:2.4K OHM,5%,0.25W	01121	CB2425
R168	315-0510-00			RES.,FXD,CMPSN:51 OHM,5%,0.25W	01121	CB5105
R170	315-0913-00			RES.,FXD,CMPSN:91K OHM,5%,0.25W	01121	CB9135
R171	316-0183-00	B010100	B032059	RES.,FXD,CMPSN:18K OHM,10%,0.25W	01121	CB1831
R171	315-0183-00	B032060		RES.,FXD,CMPSN:18K OHM,5%,0.25W	01121	CB1835
R172	316-0681-00	B010100	B032059	RES.,FXD,CMPSN:680 OHM,10%,0.25W	01121	CB6811
R172	315-0681-00	B032060		RES.,FXD,CMPSN:680 OHM,5%,0.25W	01121	CB6815
R175	316-0220-00	B010100	B032059	RES.,FXD,CMPSN:22 OHM,10%,0.25W	01121	CB2201
R175	315-0220-00	B032060		RES.,FXD,CMPSN:22 OHM,5%,0.25W	01121	CB2205
R183	316-0331-00	B010100	B032059	RES.,FXD,CMPSN:330 OHM,10%,0.25W	01121	CB3311

Replaceable Electrical Parts—AM 501

Ckt No.	Tektronix Part No.	Serial/Model No. Eff	Dscont	Name & Description	Mfr Code	Mfr Part Number
R183	315-0331-00	B032060		RES., FXD, CMPSN: 330 OHM, 5%, 0.25W	01121	CB3315
R185	316-0220-00	B010100	B032059	RES., FXD, CMPSN: 22 OHM, 10%, 0.25W	01121	CB2201
R185	315-0220-00	B032060		RES., FXD, CMPSN: 22 OHM, 5%, 0.25W	01121	CB2205
R186	316-0471-00	B010100	B032059	RES., FXD, CMPSN: 470 OHM, 10%, 0.25W	01121	CB4711
R186	315-0471-00	B032060		RES., FXD, CMPSN: 470 OHM, 5%, 0.25W	01121	CB4715
R190	315-0302-00			RES., FXD, CMPSN: 3K OHM, 5%, 0.25W	01121	CB3025
R192	315-0242-00			RES., FXD, CMPSN: 2.4K OHM, 5%, 0.25W	01121	CB2425
R193	315-0510-00			RES., FXD, CMPSN: 51 OHM, 5%, 0.25W	01121	CB5105
S120	260-1206-00			SWITCH, TOGGLE: SPDT, 5A, 115VAC CENTER OFF	09353	7103SYZQ
U10	156-0067-00			MICROCIRCUIT, LI: OPERATIONAL AMPLIFIER	80009	156-0067-00
U20	156-0067-00			MICROCIRCUIT, LI: OPERATIONAL AMPLIFIER	80009	156-0067-00
VR20	152-0283-00			SEMICONV DEVICE: ZENER, 0.4W, 43V, 5%	12954	DZ750903B1N976B
VR22	152-0255-00	B010100	B029999	SEMICONV DEVICE: ZENER, 0.4W, 51V, 5%	80009	152-0255-00
VR22	152-0283-00	B030000		SEMICONV DEVICE: ZENER, 0.4W, 43V, 5%	12954	DZ750903B1N976B
VR50	152-0461-00			SEMICONV DEVICE: ZENER, 0.4W, 6.2V, 5%	80009	152-0461-00
VR52	152-0461-00			SEMICONV DEVICE: ZENER, 0.4W, 6.2V, 5%	80009	152-0461-00
VR110	152-0175-00			SEMICONV DEVICE: ZENER, 0.4W, 5.6V, 5%	04713	SZG35008
VR126	152-0195-00			SEMICONV DEVICE: ZENER, 0.4W, 5.1V, 5%	04713	SZ11755
VR135	152-0195-00			SEMICONV DEVICE: ZENER, 0.4W, 5.1V, 5%	04713	SZ11755
VR140	152-0175-00			SEMICONV DEVICE: ZENER, 0.4W, 5.6V, 5%	04713	SZG35008

REPLACEABLE MECHANICAL PARTS

PARTS ORDERING INFORMATION

Replacement parts are available from or through your local Tektronix, Inc. Field Office or representative.

Changes to Tektronix instruments are sometimes made to accommodate improved components as they become available, and to give you the benefit of the latest circuit improvements developed in our engineering department. It is therefore important, when ordering parts, to include the following information in your order: Part number, instrument type or number, serial number, and modification number if applicable.

If a part you have ordered has been replaced with a new or improved part, your local Tektronix, Inc. Field Office or representative will contact you concerning any change in part number.

Change information, if any, is located at the rear of this manual.

SPECIAL NOTES AND SYMBOLS

X000 Part first added at this serial number
00X Part removed after this serial number

FIGURE AND INDEX NUMBERS

Items in this section are referenced by figure and index numbers to the illustrations.

INDENTATION SYSTEM

This mechanical parts list is indented to indicate item relationships. Following is an example of the indentation system used in the description column.

```

1 2 3 4 5           Name & Description
Assembly and/or Component
Attaching parts for Assembly and/or Component
    --- * ---
Detail Part of Assembly and/or Component
Attaching parts for Detail Part
    --- * ---
Parts of Detail Part
Attaching parts for Parts of Detail Part
    --- * ---
  
```

Attaching Parts always appear in the same indentation as the item it mounts, while the detail parts are indented to the right. Indented items are part of, and included with, the next higher indentation. The separation symbol --- * --- indicates the end of attaching parts.

Attaching parts must be purchased separately, unless otherwise specified.

ITEM NAME

In the Parts List, an Item Name is separated from the description by a colon (:). Because of space limitations, an Item Name may sometimes appear as incomplete. For further Item Name identification, the U.S. Federal Cataloging Handbook H6-1 can be utilized where possible.

ABBREVIATIONS

"	INCH	ELCTRN	ELECTRON	IN	INCH	SE	SINGLE END
#	NUMBER SIZE	ELEC	ELECTRICAL	INCAND	INCANDESCENT	SECT	SECTION
ACTR	ACTUATOR	ELCTLT	ELECTROLYTIC	INSUL	INSULATOR	SEMICOND	SEMICONDUCTOR
ADPTR	ADAPTER	ELEM	ELEMENT	INTL	INTERNAL	SHLD	SHIELD
ALIGN	ALIGNMENT	EPL	ELECTRICAL PARTS LIST	LPHLDR	LAMPHOLDER	SHLDR	SHOULDERED
AL	ALUMINUM	EQPT	EQUIPMENT	MACH	MACHINE	SKT	SOCKET
ASSEM	ASSEMBLED	EXT	EXTERNAL	MECH	MECHANICAL	SL	SLIDE
ASSY	ASSEMBLY	FIL	FILLISTER HEAD	MTG	MOUNTING	SLFLKG	SELF-LOCKING
ATTEN	ATTENUATOR	FLEX	FLEXIBLE	NIP	NIPPLE	SLVG	SLEEVEING
AWG	AMERICAN WIRE GAGE	FLH	FLAT HEAD	NON WIRE	NOT WIRE WOUND	SPR	SPRING
BD	BOARD	FLTR	FILTER	OB	ORDER BY DESCRIPTION	SQ	SQUARE
BRKT	BRACKET	FR	FRAME or FRONT	OD	OUTSIDE DIAMETER	SST	STAINLESS STEEL
BRS	BRASS	FSTNR	FASTENER	OVH	OVAL HEAD	STL	STEEL
BRZ	BRONZE	FT	FOOT	PH BRZ	PHOSPHOR BRONZE	SW	SWITCH
BSHG	BUSHING	FXD	FIXED	PL	PLAIN or PLATE	T	TUBE
CAB	CABINET	GSKT	GASKET	PLSTC	PLASTIC	TERM	TERMINAL
CAP	CAPACITOR	HDL	HANDLE	PN	PART NUMBER	THD	THREAD
CER	CERAMIC	HEX	HEXAGON	PNH	PAN HEAD	THK	THICK
CHAS	CHASSIS	HEX HD	HEXAGONAL HEAD	PWR	POWER	TNSN	TENSION
CKT	CIRCUIT	HEX SOC	HEXAGONAL SOCKET	RCPT	RECEPTACLE	TPG	TAPPING
COMP	COMPOSITION	HLCPS	HELICAL COMPRESSION	RES	RESISTOR	TRH	TRUSS HEAD
CONN	CONNECTOR	HLEXT	HELICAL EXTENSION	RGD	RIGID	V	VOLTAGE
COV	COVER	HV	HIGH VOLTAGE	RLF	RELIEF	VAR	VARIABLE
COPLG	COUPLING	IC	INTEGRATED CIRCUIT	RTNR	RETAINER	W/	WITH
CRT	CATHODE RAY TUBE	ID	INSIDE DIAMETER	SCH	SOCKET HEAD	WSHR	WASHER
DEG	DEGREE	IDENT	IDENTIFICATION	SCOPE	OSCILLOSCOPE	XFMR	TRANSFORMER
DWR	DRAWER	IMPLR	IMPELLER	SCR	SCREW	XSTR	TRANSISTOR

CROSS INDEX—MFR. CODE NUMBER TO MANUFACTURER

Mfr. Code	Manufacturer	Address	City, State, Zip
04713	MOTOROLA, INC., SEMICONDUCTOR PROD. DIV.	5005 E MCDOWELL RD, PO BOX 20923	PHOENIX, AZ 85036
09353	C AND K COMPONENTS, INC.	103 MORSE STREET	WATERTOWN, MA 02172
13511	AMPHENOL CARDRE DIV., BUNKER RAMO CORP.		LOS GATOS, CA 95030
22526	BERG ELECTRONICS, INC.	YOUK EXPRESSWAY	NEW CUMBERLAND, PA 17070
45722	USM CORP., PARKER-KALON FASTENER DIV.		CAMPBELLSVILLE, KY 42718
58474	SUPERIOR ELECTRIC CO.	383 MIDDLE ST.	BRISTOL, CT 06010
71785	TRW, CINCH CONNECTORS	1501 MORSE AVENUE	ELK GROVE VILLAGE, IL 60007
73743	FISCHER SPECIAL MFG. CO.	446 MORGAN ST.	CINCINNATI, OH 45206
73803	TEXAS INSTRUMENTS, INC., METALLURGICAL MATERIALS DIV.	34 FOREST STREET	ATTLEBORO, MA 02703
78189	ILLINOIS TOOL WORKS, INC. SHAKEPROOF DIVISION	ST. CHARLES ROAD	ELGIN, IL 60120
79807	WROUGHT WASHER MFG. CO.	2100 S. O BAY ST.	MILWAUKEE, WI 53207
80009	TEKTRONIX, INC.	P O BOX 500	BEAVERTON, OR 97077
83385	CENTRAL SCREW CO.	2530 CRESCENT DR.	BROADVIEW, IL 60153
93907	CAMCAR SCREW AND MFG. CO.	600 18TH AVE.	ROCKFORD, IL 61101

Fig. & Index No.	Tektronix Part No.	Serial/Model No. Eff	Dscont	Qty	1	2	3	4	5	Name & Description	Mfr Code	Mfr Part Number
1-1	337-1399-00			2						SHLD,ELECTRICAL:SIDE	80009	337-1399-00
-2	351-0392-00			1						SLIDE:INFORMATION	80009	351-0392-00
-3	129-0064-00			2						POST,BDG,ELEC:CHARCOAL,5-WAY MINIATURE (ATTACHING PARTS)	58474	BINP BB10167G13T
-4	210-0457-00			2						NUT,PL,ASSEM WA:6-32 X 0.312 INCH,STL	83385	OBD
-5	358-0181-00			2						INSULATOR,BSHG:CHARCOAL	58474	BB10166G13BX
-6	129-0064-01			2						POST,BDG,ELEC:RED,5-WAY MINIATURE (ATTACHING PARTS)	58474	BB10167G2BX
-7	210-0457-00			2						NUT,PL,ASSEM WA:6-32 X 0.312 INCH,STL	83385	OBD
-8	358-0181-01			2						INSULATOR,BSHG:RED	58474	BB10166G2
-9	129-0064-03			2						POST,BDG,ELEC:GREEN,5-WAY MINIATURE (ATTACHING PARTS)	58474	DF21GNC
-10	210-0457-00			2						NUT,PL,ASSEM WA:6-32 X 0.312 INCH,STL	83385	OBD
-11	129-0103-00			1						POST,BDG,ELEC:ASSEMBLY (ATTACHING PARTS)	80009	129-0103-00
-12	210-0455-00			1						NUT,PLAIN,HEX.:0.25-28 X 0.375 INCH,BRASS	73743	3089-402
-13	210-0046-00			1						WASHER,LOCK:INTL,0.26 ID X 0.40" OD,STL	78189	1214-05-00-0541C
	-----			-						. POST ASSEMBLY INCLUDES:		
	200-0103-00			1						. NUT,PLAIN,KNURL:0.25-28 X 0.375" OD,BRASS	80009	200-0103-00
	129-0077-00			1						. STUD,SHOULDERED:0.938 INCH LONG,BRASS	80009	129-0077-00
-14	131-0955-00			3						CONNECTOR,RCPT,:BNC,FEMALE,W/HARDWARE	13511	31-279
	214-1840-00	B010100	B031999X	1						PIN,KNOB SECRC:0.094 OD X 0.120 INCH LONG	80009	214-1840-00
	366-1422-01	B010100	B031999	1						KNOB:LATCH	80009	366-1422-01
-15	366-1690-00	B032000		1						KNOB,LATCH:SL GY,0.53 X0.23 X 1.059	80009	366-1690-00
-16	260-1206-00			1						SWITCH,TOGGLE:SPDT,5A,115VAC CENTER OFF (ATTACHING PARTS)	09353	7103SYZQ
-17	210-0562-00			1						NUT,PLAIN,HEX.:0.25-40 X 0.312 INCH,BBS	73743	2X20224-402
-18	210-0940-00			1						WASHER,FLAT:0.25 ID X 0.375 INCH OD,STL	79807	OBD
-19	333-1792-00			1						PANEL,FRONT:	80009	333-1792-00
-20	331-0365-00			1						WINDOW,INFO SL:INFORMATION	80009	331-0365-00
-21	200-0935-00			1						BASE,LAMPHOLDER:0.29 OD X 0.19 CASE	80009	200-0935-00
-22	378-0602-00			1						LENS,LIGHT:GREEN	80009	378-0602-00
-23	352-0157-00			1						LAMPHOLDER:WHITE PLASTIC	80009	352-0157-00
-24	214-1513-01	B010100	B031999	1						LCH,PLUG-IN RET:	80009	214-1513-01
	105-0719-00	B032000		1						LATCH,RETAINING:PLUG-IN (ATTACHING PARTS)	80009	105-0719-00
-25	213-0254-00			1						SCREW,TPG,TF:2-32 X 0.250,100 DEG,FLH	45722	OBD
-26	105-0718-00	X032000	B032429	1						BAR,LATCH RLSE:	80009	105-0718-00
	105-0718-01	B032430		1						BAR,LATCH RLSE:	80009	105-0718-01
-27	386-2711-00			1						SUBPANEL,FRONT: (ATTACHING PARTS)	80009	386-2711-00
-28	213-0229-00	B010100	B032529	4						SCR,TPG,THD FOR:6-20 X0.375"100 DEG,FLH STL	93907	OBD
	213-0123-00	B032530		4						SCREW,TPG,TF:6-32 X 0.375,SPCL TYPE,FLH	93907	OBD
-29	337-1913-00			1						SHLD,ELECTRICAL:FRONT SUBPANEL	80009	337-1913-00
-30	214-1061-00			1						SPRING,GROUND:FLAT	80009	214-1061-00
-31	-----			1						CKT BOARD ASSY:--MAIN(SEE A1 EPL) (ATTACHING PARTS)		
-32	213-0146-00			4						SCR,TPG,THD FOR:6-20 X 0.313 INCH,PNH STL	83385	OBD
-33	211-0025-00			4						SCREW,MACHINE:4-40 X 0.375 100 DEG,FLH STL	83385	OBD
-34	210-0586-00			4						NUT,PLAIN,EXT W:4-40 X 0.25 INCH,STL	78189	211-041800-00
-35	210-1122-00			4						WASHER,LOCK:0.228 ID X 0.375 INCH OD,STL	04713	B52200F006
-36	210-0921-00			2						WASHER,MICA:0.50 X 0.141 X0.005 INCH THK	80009	210-0921-00
-37	342-0163-00			2						INSULATOR,PLATE:XSTR,0.675 X 0.625 X 0.001"	80009	342-0163-00

Replaceable Mechanical Parts—AM 501

Fig. & Index No.	Tektronix Part No.	Serial/Model No. Eff Dscont	Qty	1	2	3	4	5	Name & Description	Mfr Code	Mfr Part Number
	-----	-----	-						. CKT BOARD ASSEMBLY INCLUDES:		
1-38	136-0252-04	B010100 B020280	85						. SOCKET,PIN TERM:U/W 0.016-0.018 DIA PINS	22526	75060-007
	136-0252-04	B020281	45						. SOCKET,PIN TERM:U/W 0.016-0.018 DIA PINS	22526	75060-007
	136-0235-00	B020281	4						. SOCKET,PLUG-IN:6 CONTACT,ROUND	71785	133-96-12-062
	136-0514-00	B020281	2						. SKT,PL-IN ELEC:MICROCIRCUIT,8 DIP	73803	CS9002-8
-39	214-0579-00		2						. TERM,TEST POINT:BRS CD PL	80009	214-0579-00
-40	426-0725-06		1						FR SECT,PLUG-IN:TOP	80009	426-0725-06
-41	386-3657-00	XB032000 B032619	2						SUPPORT,PLUG-IN:	80009	386-3657-00
	386-3657-01	B032620	2						SUPPORT,PLUG IN:	93907	OBD
-42	210-1270-00	XB032000	2						WASHER,FLAT:0.141 ID X 0.04 THK,AL	80009	210-1270-00
-43	426-0724-05		1						FR SECT,PLUG-IN:BOTTOM	80009	426-0724-05

ACCESSORIES

Fig. & Index No.	Tektronix Part No.	Serial/Model No.		Qty						Name & Description	Mfr Code	Mfr Part Number
		Eff	Dscont		1	2	3	4	5			
	070-1616-01			1						MANUAL, TECH: INSTRUCTION	80009	070-1616-01

MANUAL CHANGE INFORMATION

At Tektronix, we continually strive to keep up with latest electronic developments by adding circuit and component improvements to our instruments as soon as they are developed and tested.

Sometimes, due to printing and shipping requirements, we can't get these changes immediately into printed manuals. Hence, your manual may contain new change information on following pages.

A single change may affect several sections. Since the change information sheets are carried in the manual until all changes are permanently entered, some duplication may occur. If no such change pages appear following this page, your manual is correct as printed.

SERVICE NOTE

Because of the universal parts procurement problem, some electrical parts in your instrument may be different from those described in the Replaceable Electrical Parts List. The parts used will in no way alter or compromise the performance or reliability of this instrument. They are installed when necessary to ensure prompt delivery to the customer. Order replacement parts from the Replaceable Electrical Parts List.

CALIBRATION TEST EQUIPMENT REPLACEMENT

Calibration Test Equipment Chart

This chart compares TM 500 product performance to that of older Tektronix equipment. Only those characteristics where significant specification differences occur, are listed. In some cases the new instrument may not be a total functional replacement. Additional support instrumentation may be needed or a change in calibration procedure may be necessary.

Comparison of Main Characteristics

DM 501 replaces 7D13		
PG 501 replaces 107 108	PG 501 - Risetime less than 3.5 ns into 50 Ω. PG 501 - 5 V output pulse; 3.5 ns Risetime	107 - Risetime less than 3.0 ns into 50 Ω. 108 - 10 V output pulse 1 ns Risetime
PG 502 replaces 107 108 111	PG 502 - 5 V output PG 502 - Risetime less than 1 ns; 10 ns Pretrigger pulse delay	108 - 10 V output 111 - Risetime 0.5 ns; 30 to 250 ns Pretrigger pulse delay
PG 508 replaces 114 115 2101	Performance of replacement equipment is the same or better than equipment being replaced.	
PG 506 replaces 106 067-0502-01	PG 506 - Positive-going trigger output signal at least 1 V; High Amplitude output, 60 V. PG 506 - Does not have chopped feature.	106 - Positive and Negative-going trigger output signal, 50 ns and 1 V; High Amplitude output, 100 V. 0502-01 - Comparator output can be alternately chopped to a reference voltage.
SG 503 replaces 190, 190A, 190B 191 067-0532-01	SG 503 - Amplitude range 5 mV to 5.5 V p-p. SG 503 - Frequency range 250 kHz to 250 MHz.	190B - Amplitude range 40 mV to 10 V p-p. 0532-01 - Frequency range 65 MHz to 500 MHz.
SG 504 replaces 067-0532-01 067-0650-00	SG 504 - Frequency range 245 MHz to 1050 MHz.	0532-01 - Frequency range 65 MHz to 500 MHz.
TG 501 replaces 180, 180A 181 184 2901	TG 501 - Trigger output-slaved to marker output from 5 sec through 100 ns. One time-mark can be generated at a time. TG 501 - Trigger output-slaved to market output from 5 sec through 100 ns. One time-mark can be generated at a time. TG 501 - Trigger output-slaved to marker output from 5 sec through 100 ns. One time-mark can be generated at a time.	180A - Trigger pulses 1, 10, 100 Hz; 1, 10, and 100 kHz. Multiple time-marks can be generated simultaneously. 181 - Multiple time-marks 184 - Separate trigger pulses of 1 and 0.1 sec; 10, 1, and 0.1 ms; 10 and 1 μs. 2901 - Separate trigger pulses, from 5 sec to 0.1 μs. Multiple time-marks can be generated simultaneously.

NOTE: All TM 500 generator outputs are short-proof. All TM 500 plug-in instruments require TM 500-Series Power Module.